

# LEVEL 7

<b>Number</b>	<i>Page</i>
N22... Rounding to 1 Significant Figure .....	104
<b>Calculating</b>	
C26... Percentage Increase and Decrease .....	105
C27... Addition and Subtraction of Fractions.....	106
C28... Multiplication and Division of Fractions .....	107
C29... Numbers Between 0 and 1 (Mult. & Div.) .....	108
C30... Estimating Answers .....	109
C31... Using a Calculator .....	110
<b>Algebra</b>	
A16... Further Algebraic Simplification .....	111
A17... Expanding Brackets .....	112
A18... Factorisation .....	113
A19... Solving Difficult Equations .....	114
A20... Rearranging a Formula .....	115
A21... Trial and Improvement.....	116A, 116B
A22... Inequalities .....	117
A23... Solving Inequalities .....	118
A24... Understanding Straight Line Graphs .....	119
A25... Regions .....	120
A26... Simultaneous Equations Graphically .....	121
A27... Simultaneous Equations Algebraically .....	122
A28... $n$ th Term of Quadratic Sequences .....	123
A29... Graphs of Quadratic and Cubic Functions .....	124A, 124B, 124C
<b>Shape, Space and Measure</b>	
S30... Pythagoras' Theorem .....	125A, 125B, 125C
S31... Areas of Compound Shapes .....	126A, 126B, 126C
S32... Volumes of Prisms.....	127
S33... Surface Area of Triangular Prisms.....	128
S34... Loci.....	129
S35... Enlargement by a Negative Scale Factor .....	130
S36... Bounds .....	131
S37... Compound Measures .....	132
<b>Handling Data</b>	
D14... Averages from Tables .....	133A, 133B
D15... Relative Frequency .....	134

## Level 7

[N22](#) [C26](#) [C27](#) [C28](#) [C29](#) [C30](#) [C31](#) [A16](#) [A17](#) [A18](#) [A19](#) [A20](#) [A21](#) [A22](#) [A23](#) [A24](#) [A25](#)  
[A26](#) [A27](#) [A28](#) [A29](#) [S30](#) [S31](#) [S32](#) [S33](#) [S34](#) [S35](#) [S36](#) [S37](#) [D14](#) [D15](#)

# N22

## Rounding to 1 Significant Figure

1) Round the following to 1 significant figure.

- a) 478 cm
- b) 450 cm
- c) 449 cm
- d) 12761 m
- e) 28481 km

2) Round the following to 1 significant figure.

- a) 673.8 cm
- b) 4017.9 kg
- c) 246.83 m
- d) £45.38
- e) 20482.1 kg

3) Round the following to 1 significant figure.

- a) 0.26 ml
- b) 0.043 g
- c) 0.0671 m
- d) 0.000256 km
- e) 0.3822 m

4) Round the following to 1 significant figure.

- a) 962 m
- b) 0.923 cm
- c) 0.971 cm
- d) 0.096 km
- e) 0.00985 km

5) Round the following to 1 significant figure.

- a) £631428
- b) 0.00573 g
- c) £3614.68
- d) 0.493 ml
- e) £968

Level 7

[N22](#) [C26](#) [C27](#) [C28](#) [C29](#) [C30](#) [C31](#) [A16](#) [A17](#) [A18](#) [A19](#) [A20](#) [A21](#) [A22](#) [A23](#) [A24](#) [A25](#)  
[A26](#) [A27](#) [A28](#) [A29](#) [S30](#) [S31](#) [S32](#) [S33](#) [S34](#) [S35](#) [S36](#) [S37](#) [D14](#) [D15](#)

# C26

## Percentage Increase and Decrease

- 1)
  - a) Increase £400 by 16%
  - b) Increase £750 by 24%
  - c) Increase £2000 by 38%
  - d) Increase £14500 by 19%
  - e) Increase £16.50 by 30%
  
- 2)
  - a) Decrease £700 by 32%
  - b) Decrease £36 by 14%
  - c) Decrease £1970 by 40%
  - d) Decrease £3000 by 12.5%
  - e) Decrease £3124 by 16.25%
  
- 3) A sports shop reduces the price of all its trainers by 15% in the Spring sale. Before the sale, one pair of trainers cost £74. How much are they after the reduction?
  
- 4) Tim took up weightlifting. In his first session he could bench-press 45 kg. Four weeks later he could bench-press 22% more. How much could he now lift to the nearest kg?
  
- 5) If a manager of a shop reduces the price of a £1500 piano by 15% and then, four weeks later, increases the reduced price by 15%, how much does it now cost?

### Level 7

[N22](#) [C26](#) [C27](#) [C28](#) [C29](#) [C30](#) [C31](#) [A16](#) [A17](#) [A18](#) [A19](#) [A20](#) [A21](#) [A22](#) [A23](#) [A24](#) [A25](#)  
[A26](#) [A27](#) [A28](#) [A29](#) [S30](#) [S31](#) [S32](#) [S33](#) [S34](#) [S35](#) [S36](#) [S37](#) [D14](#) [D15](#)

# C27

## Addition and Subtraction of Fractions

1) Work out

a)  $\frac{1}{3} + \frac{1}{2}$

b)  $\frac{3}{5} + \frac{1}{4}$

c)  $\frac{2}{7} + \frac{3}{5}$

d)  $\frac{1}{2} + \frac{2}{9}$

e)  $\frac{3}{10} + \frac{3}{7}$

3) Work out

a)  $1\frac{2}{3} + \frac{3}{4}$

b)  $2\frac{1}{2} + \frac{5}{7}$

c)  $\frac{2}{5} + 3\frac{1}{2}$

d)  $1\frac{7}{10} + \frac{1}{5}$

e)  $2\frac{3}{4} + \frac{5}{6}$

5) Work out

a)  $\frac{2}{3} - \frac{1}{2}$

b)  $\frac{3}{4} - \frac{2}{3}$

c)  $\frac{4}{5} - \frac{3}{4}$

d)  $\frac{5}{6} - \frac{2}{3}$

e)  $\frac{3}{4} - \frac{3}{8}$

7) Work out

a)  $4\frac{1}{2} - 2\frac{1}{2}$

b)  $1\frac{2}{5} - 1\frac{1}{10}$

c)  $3\frac{2}{3} - 1\frac{11}{15}$

d)  $2\frac{3}{4} - 1\frac{5}{8}$

e)  $5\frac{2}{3} - 1\frac{4}{9}$

2) Work out

a)  $\frac{2}{3} + \frac{1}{6}$

b)  $\frac{3}{5} + \frac{3}{10}$

c)  $\frac{1}{2} + \frac{4}{5}$

d)  $\frac{5}{6} + \frac{3}{5}$

e)  $\frac{7}{12} + \frac{3}{4}$

4) Work out

a)  $2\frac{1}{2} + 1\frac{1}{5}$

b)  $1\frac{3}{4} + 1\frac{2}{3}$

c)  $3\frac{1}{6} + 1\frac{1}{3}$

d)  $2\frac{2}{9} + 1\frac{2}{3}$

e)  $4\frac{1}{2} + 2\frac{3}{10}$

6) Work out

a)  $1\frac{3}{4} - \frac{1}{2}$

b)  $2\frac{4}{5} - \frac{3}{4}$

c)  $3\frac{1}{6} - \frac{2}{3}$

d)  $2\frac{2}{9} - \frac{5}{6}$

e)  $6\frac{1}{2} - \frac{7}{8}$

8) Work out

a)  $3\frac{4}{5} + 1\frac{1}{2}$

b)  $4\frac{2}{9} - \frac{5}{6}$

c)  $2\frac{3}{8} + 1\frac{5}{6}$

d)  $2 - 1\frac{5}{8}$

e)  $5 - 2\frac{1}{7}$

9) Find the perimeter of the rectangle below. Give your answer as a mixed number.

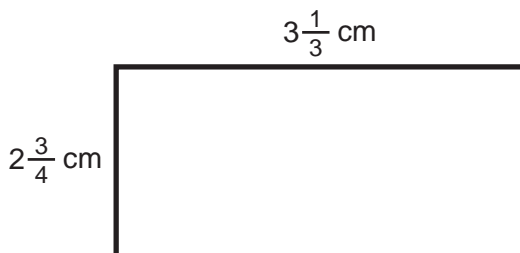

10) Find the perimeter of the triangle below. Give your answer as a mixed number.

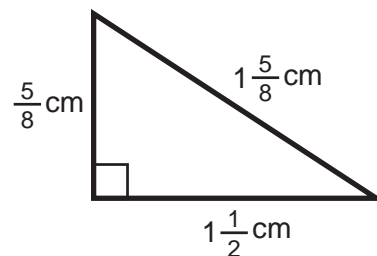

11) If a length of copper tubing is  $20\frac{1}{4}$  cm long and Jim cuts off a piece that is  $17\frac{3}{5}$  cm long, what is the length of the copper tubing left over?

Level 7

N22 C26 **C27** C28 C29 C30 C31 A16 A17 A18 A19 A20 A21 A22 A23 A24 A25  
A26 A27 A28 A29 S30 S31 S32 S33 S34 S35 S36 S37 D14 D15

# C28

## Multiplication and Division of Fractions

1) Work out

a)  $\frac{1}{2} \times \frac{3}{4}$

b)  $\frac{2}{3} \times \frac{4}{5}$

c)  $\frac{10}{11} \times \frac{2}{3}$

d)  $\frac{4}{9} \times \frac{2}{5}$

e)  $\frac{4}{7} \times \frac{1}{9}$

3) Work out

a)  $1\frac{1}{2} \times \frac{8}{9}$

b)  $2\frac{2}{3} \times \frac{6}{7}$

c)  $\frac{6}{11} \times 1\frac{1}{8}$

d)  $4\frac{2}{5} \times \frac{10}{11}$

e)  $3\frac{3}{4} \times \frac{8}{9}$

5) Work out

a)  $\frac{2}{3} \div \frac{1}{2}$

b)  $\frac{3}{4} \div \frac{2}{3}$

c)  $\frac{2}{5} \div \frac{3}{4}$

d)  $\frac{3}{7} \div \frac{6}{11}$

e)  $\frac{3}{4} \div \frac{3}{8}$

7) Work out

a)  $2\frac{1}{2} \div 3\frac{1}{2}$

b)  $3\frac{2}{5} \div 1\frac{1}{10}$

c)  $4\frac{1}{3} \div 1\frac{11}{15}$

d)  $2\frac{3}{4} \div 1\frac{5}{8}$

e)  $5\frac{2}{3} \div 1\frac{4}{9}$

2) Work out

a)  $\frac{2}{3} \times \frac{3}{5}$

b)  $\frac{3}{7} \times \frac{5}{6}$

c)  $\frac{8}{9} \times \frac{6}{10}$

d)  $\frac{1}{2} \times \frac{8}{9}$

e)  $\frac{7}{10} \times \frac{5}{21}$

4) Work out

a)  $2\frac{1}{2} \times 2\frac{1}{5}$

b)  $3\frac{3}{4} \times 2\frac{2}{3}$

c)  $4\frac{1}{6} \times 2\frac{2}{5}$

d)  $2\frac{2}{9} \times 1\frac{1}{5}$

e)  $3\frac{4}{7} \times 1\frac{13}{15}$

6) Work out

a)  $\frac{3}{4} \div 1\frac{1}{5}$

b)  $\frac{4}{7} \div 1\frac{7}{9}$

c)  $2\frac{1}{4} \div \frac{6}{7}$

d)  $2\frac{3}{5} \div \frac{9}{10}$

e)  $1\frac{1}{2} \div \frac{3}{8}$

8) Work out

a)  $\frac{2}{3} \div 2$

b)  $1\frac{3}{4} \div 14$

c)  $4 \div \frac{2}{5}$

d)  $5 \div \frac{3}{4}$

e)  $3\frac{1}{2} \div 4$

9) Find the area of the rectangle below.  
Give your answer as a mixed number.

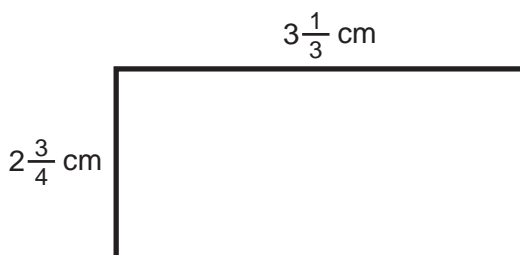

10) Find the area of the triangle below.  
Give your answer as a mixed number.

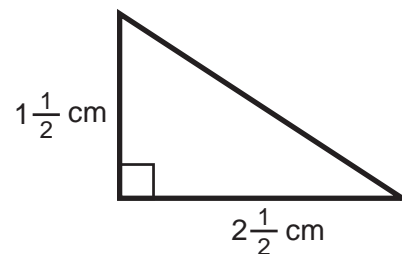

11) Jim has a length of copper tubing which is 85 cm long.  
He wants to cut it into pieces which are  $4\frac{1}{4}$  cm long.  
If there is no wastage, how many pieces will Jim get?

Level 7

N22 C26 C27 **C28** C29 C30 C31 A16 A17 A18 A19 A20 A21 A22 A23 A24 A25  
A26 A27 A28 A29 S30 S31 S32 S33 S34 S35 S36 S37 D14 D15

# C29 Numbers Between 0 and 1 (Multiplication and Division)

1) Work out the answers to the following:

- a)  $24 \times 0.2$
- b)  $13 \times 0.4$
- c)  $60 \times 0.7$
- d)  $243 \times 0.2$
- e)  $0.6 \times 700$

2) Work out the answers to the following:

- a)  $314 \times 0.02$
- b)  $836 \times 0.001$
- c)  $800 \times 0.006$
- d)  $418 \times 0.003$
- e)  $411 \times 0.09$

3) Work out the answers to the following:

- a)  $0.2 \times 0.4$
- b)  $0.1 \times 0.03$
- c)  $0.02 \times 0.06$
- d)  $0.08 \times 0.003$
- e)  $0.05 \times 0.08$

4) Work out the answers to the following:

- a)  $62 \times 0.14$
- b)  $2.7 \times 2.5$
- c)  $613 \times 0.042$
- d)  $42.3 \times 1.8$
- e)  $228 \times 0.063$

5) Work out the answers to the following:

- a)  $6 \div 0.2$
- b)  $8 \div 0.1$
- c)  $9 \div 0.3$
- d)  $4 \div 0.02$
- e)  $7 \div 0.002$

6) Work out the answers to the following:

- a)  $62 \div 0.2$
- b)  $51 \div 0.3$
- c)  $4.56 \div 0.04$
- d)  $22.5 \div 0.05$
- e)  $14.7 \div 0.007$

7) Work out the answers to the following:

- a)  $7.24 \div 0.2$
- b)  $8.13 \div 0.3$
- c)  $1.512 \div 0.07$
- d)  $0.16 \div 0.008$
- e)  $0.0732 \div 0.04$

8) Work out the answers to the following:

- a)  $0.718 \div 0.2$
- b)  $0.0141 \div 0.003$
- c)  $0.24 \div 0.012$
- d)  $1.625 \div 0.0013$
- e)  $47.1 \div 0.15$

Level 7

[N22](#) [C26](#) [C27](#) [C28](#) [C29](#) [C30](#) [C31](#) [A16](#) [A17](#) [A18](#) [A19](#) [A20](#) [A21](#) [A22](#) [A23](#) [A24](#) [A25](#)  
[A26](#) [A27](#) [A28](#) [A29](#) [S30](#) [S31](#) [S32](#) [S33](#) [S34](#) [S35](#) [S36](#) [S37](#) [D14](#) [D15](#)

# C30

## Estimating Answers

1) Estimate the value of:

- a)  $21 \times 34$
- b)  $42 \times 56$
- c)  $17 \times 62$
- d)  $29 \times 78$
- e)  $66 \times 96$

2) Estimate the value of:

- a)  $510 \times 724$
- b)  $86 \times 2146$
- c)  $753 \times 184$
- d)  $48 \times 6315$
- e)  $3642 \times 1356$

3) Estimate the value of:

- a)  $\frac{61}{19}$
- b)  $\frac{76}{43}$
- c)  $\frac{362}{78}$
- d)  $\frac{738}{96}$
- e)  $\frac{416}{781}$

4) Estimate the value of:

- a)  $\frac{357}{12 \times 23}$
- b)  $\frac{924}{34 \times 13}$
- c)  $\frac{172 \times 411}{430}$
- d)  $\frac{625 \times 43}{16 \times 38}$
- e)  $\frac{972 \times 368}{17 \times 23 \times 18}$

5) Estimate the value of:

- a)  $8 \div 0.12$
- b)  $6 \div 0.24$
- c)  $5 \div 0.49$
- d)  $7 \div 0.012$
- e)  $23 \div 0.18$

6) Estimate the value of:

- a)  $\frac{24 \times 510}{0.53}$
- b)  $\frac{46 \times 6.2}{0.135}$
- c)  $\frac{215 \times 38}{0.183}$
- d)  $\frac{18.3 \times 31.2}{0.017}$
- e)  $\frac{405 \times 274}{0.488}$

Level 7

[N22](#) [C26](#) [C27](#) [C28](#) [C29](#) [C30](#) [C31](#) [A16](#) [A17](#) [A18](#) [A19](#) [A20](#) [A21](#) [A22](#) [A23](#) [A24](#) [A25](#)  
[A26](#) [A27](#) [A28](#) [A29](#) [S30](#) [S31](#) [S32](#) [S33](#) [S34](#) [S35](#) [S36](#) [S37](#) [D14](#) [D15](#)

# C31

## Using a Calculator

1) Using a calculator, work out the value of:

- a)  $24 + 16 \div 4$
- b)  $3 + 8 \div 2 \times 3$
- c)  $60 \times 2 - 20 \div 4$
- d)  $(2 + 7 \times 8) \times 4$
- e)  $(3 + 7) \times (8 - 2)$

2) Using a calculator, work out the value of:

- a)  $6^3 - (2^4 + 3^5)$
- b)  $(3^7 - 2^6) \div 10^4$
- c)  $2^8 \div 2^3 \times 5^2$
- d)  $5^3 \times 3^5$
- e)  $2^{20} - 3^8$

3) Using a calculator, work out the value of:

- a)  $\sqrt{256} \times 2^4 - \sqrt{169}$
- b)  $\sqrt{365} \times \sqrt{365}$
- c)  $\sqrt{550 - 21}$
- d)  $\sqrt{2^8 + 3^4 - 13}$
- e)  $\sqrt{4^6 \times 2^8} \div (3^2 - 1)$

4) Using a calculator, work out the value of:

- a)  $\frac{7 + 4 \times 8}{18 - 5}$
- b)  $\frac{6^3 - 2^3}{(3^2 + 7) \div 2}$
- c)  $\frac{\sqrt{729} + 21}{\sqrt{64}}$
- d)  $\frac{62 \times 2^4 + 2^3}{\sqrt{4^3 + 3^2 + 3^3}}$
- e)  $\frac{284 - \sqrt{2^9 - 112}}{(3 + 17) \times \sqrt{100}}$

Level 7



# A16

## Further Algebraic Simplification

1) Simplify the following

- a)  $6 \times x$
- b)  $2 \times x \times y$
- c)  $6 \times x \times 3 \times y$
- d)  $s \times t \times u$
- e)  $7 \times s \times 2 \times t \times u$

2) Simplify the following

- a)  $x \times x \times x \times x$
- b)  $t \times t \times t \times t \times t \times t \times t$
- c)  $g \times g$
- d)  $x \times x \times x \times y \times y \times y \times y$
- e)  $x \times y \times x \times y \times y$

3) Simplify the following

- a)  $x \times x^2$
- b)  $y^3 \times y^4$
- c)  $x^2 \times x^3 \times x$
- d)  $g \times g \times g^2 \times g^4$
- e)  $x^2 \times x^3 \times x^4 \times x^5$

4) Simplify the following

- a)  $3x^2 \times 2x^3$
- b)  $5x \times 4x^2$
- c)  $6y^3 \times 2y^4$
- d)  $9x^2 \times x^3$
- e)  $4x^3 \times 2x \times 3x^2$

5) Simplify the following

- a)  $3x^2y^3 \times 2x^3y^4$
- b)  $2xy^4 \times 3x^2y$
- c)  $5x^3y^4 \times 2x^2y^2$
- d)  $2x^2y \times x^4y^2$
- e)  $3x^3y \times 2xy^2 \times 3x^2y^2$

6) Simplify the following

- a)  $x^8 \div x^2$
- b)  $9y^6 \div 3y^2$
- c)  $14y^3 \div 2y^2$
- d)  $20x^5 \div 4x$
- e)  $16x^8 \div 8x^2$

7) Simplify the following

- a)  $\frac{12x^6}{3x^2}$
- b)  $\frac{20x^3}{2x}$
- c)  $\frac{5x^4}{x^2}$
- d)  $\frac{6x^5}{3x^3}$
- e)  $\frac{300x^9}{10x^2}$

8) Simplify the following

- a)  $\frac{12x^3y}{4x}$
- b)  $\frac{15x^4y^3}{3xy}$
- c)  $\frac{20x^3y^6}{4x^2y^3}$
- d)  $\frac{14x^2y^2}{7xy}$
- e)  $\frac{30x^2y^3z^6}{3xy^2z^4}$

9) Find the value of

- a)  $4^0$
- b)  $6^0$
- c)  $12^0$
- d)  $z^0$
- e)  $x^0$

Level 7

# A17

## Expanding Brackets

- 1) Expand
- a)  $2(x + 3)$
  - b)  $2(x - 4)$
  - c)  $5(2x + 1)$
  - d)  $7(3x - 1)$
  - e)  $4(2a + 7)$
- 2) Expand
- a)  $2x(3x + 1)$
  - b)  $3x(4x - 2)$
  - c)  $2x(x + 1)$
  - d)  $3x(2x - y)$
  - e)  $5x(3x + 2y)$
- 3) Expand and simplify
- a)  $2(x + 3) + 4(x + 1)$
  - b)  $3(2x + 1) + 2(5x + 2)$
  - c)  $4(x + 1) + 3(3x + 4)$
  - d)  $6(2x + 3) + 5(x + 2)$
  - e)  $4(3x + 2) + 5(2x + 1)$
- 4) Expand and simplify
- a)  $2(5x + 3) + 3(x - 1)$
  - b)  $3(4x + 5) + 2(3x - 4)$
  - c)  $5(2x - 1) + 3(2x + 5)$
  - d)  $2(3x - 4) + 3(x + 2)$
  - e)  $3(2x - 1) + 4(3x - 2)$
- 5) Expand and simplify
- a)  $3(x + 2) - 2(x + 3)$
  - b)  $4(2x + 3) - 3(2x + 1)$
  - c)  $5(3x - 2) - 2(x - 2)$
  - d)  $2(5x - 1) - 4(2x - 3)$
  - e)  $3(2x + 7) - 2(3x + 2)$
- 6) Expand and simplify
- a)  $(x + 2)(x + 2)$
  - b)  $(x + 3)(x + 5)$
  - c)  $(x + 7)(x + 1)$
  - d)  $(x + 4)(x + 3)$
  - e)  $(x + 7)(x + 2)$
- 7) Expand and simplify
- a)  $(2x + 1)(3x + 2)$
  - b)  $(4x + 3)(2x + 1)$
  - c)  $(3x + 4)(3x + 2)$
  - d)  $(5x + 2)(5x + 7)$
  - e)  $(2x + 10)(2x + 4)$
- 8) Expand and simplify
- a)  $(x + 5)(x - 3)$
  - b)  $(x - 2)(x + 4)$
  - c)  $(x - 6)(x - 2)$
  - d)  $(x + 7)(x + 3)$
  - e)  $(x - 8)(x - 2)$
- 9) Expand and simplify
- a)  $(2x - 1)(3x + 4)$
  - b)  $(5x - 2)(3x - 1)$
  - c)  $(3x + 4)(2x - 3)$
  - d)  $(5x - 1)(5x - 2)$
  - e)  $(4x + 2)(3x - 5)$
- 10) Expand and simplify
- a)  $(x + 5)^2$
  - b)  $(x - 2)^2$
  - c)  $(2x + 3)^2$
  - d)  $(3x - 1)^2$
  - e)  $(4x + 3)^2$

### Level 7

# A18

## Factorisation

1) Factorise the following

- a)  $6x - 2$
- b)  $8x + 14$
- c)  $6x + 9$
- d)  $10x - 5$
- e)  $12x + 18$

2) Factorise the following

- a)  $x^2 + x$
- b)  $t^2 - t$
- c)  $x^3 + x$
- d)  $x^5 - x^2$
- e)  $a^7 + a^4$

3) Factorise the following

- a)  $3x^2 + 6x$
- b)  $8x^3 - 2x$
- c)  $12a^2 + 4a^3$
- d)  $20x^4 - 6x^2$
- e)  $7x^3 + 8x$

4) Factorise the following

- a)  $6x^2y^4 + 4xy^3$
- b)  $4x^3y^4 + 2x^2y^2$
- c)  $10x^4y^3z - 5xy^5z$
- d)  $16a^2b^3c^4 + 3ab^2c^3$
- e)  $9x^2y^4z - 6xy^2z$

5) Factorise the following

- a)  $10x + 4$
- b)  $x^4 - x^2$
- c)  $9x^5 - 12x^2$
- d)  $12x^2y^3 + 4xy^2$
- e)  $24x^3yz^4 - 10xz^2$

Level 7

[N22](#) [C26](#) [C27](#) [C28](#) [C29](#) [C30](#) [C31](#) [A16](#) [A17](#) [A18](#) [A19](#) [A20](#) [A21](#) [A22](#) [A23](#) [A24](#) [A25](#)  
[A26](#) [A27](#) [A28](#) [A29](#) [S30](#) [S31](#) [S32](#) [S33](#) [S34](#) [S35](#) [S36](#) [S37](#) [D14](#) [D15](#)

# A19

## Solving Difficult Equations

1) Solve the following

- a)  $2x + 3 = 19$
- b)  $3x - 2 = 13$
- c)  $5x - 1 = 9$
- d)  $3 + 2x = 23$
- e)  $12 - 3x = 9$

2) Solve the following

- a)  $2(3x - 1) = 22$
- b)  $3(x + 7) = 18$
- c)  $4(5x - 2) = 12$
- d)  $66 = 6(2x + 3)$
- e)  $20 = 5(x - 6)$

3) Solve the following

- a)  $\frac{x-6}{2} = 3$
- b)  $\frac{x+8}{3} = 5$
- c)  $\frac{2x-1}{3} = 5$
- d)  $\frac{6x+1}{2} = 8$
- e)  $\frac{7x-3}{5} = 5$

4) Solve the following

- a)  $2x + 7 = x + 12$
- b)  $4x - 5 = 2x + 3$
- c)  $7x + 2 = 3x + 26$
- d)  $6x - 7 = 4x - 5$
- e)  $3x + 4 = x - 7$

5) Solve the following

- a)  $x - 6 = 2x - 13$
- b)  $3x + 4 = 5x - 8$
- c)  $4x + 17 = x - 4$
- d)  $5 - 2x = x - 7$
- e)  $2x - 1 = 14 - 3x$

6) Solve the following

- a)  $2(3x - 1) = 4x + 7$
- b)  $3(x + 4) = 2(x - 5)$
- c)  $5(2x - 3) = 3(3x + 4)$
- d)  $2(2x - 1) = 5(2x - 4)$
- e)  $2(2x + 3) = 5(x + 3)$

7) Solve the following

- a)  $\frac{2(x+1)}{3} = 6$
- b)  $\frac{4(2x-3)}{5} = 4$
- c)  $\frac{2(4x-5)}{3} = x + 10$
- d)  $\frac{3(5x+4)}{2} = 7x - 8$
- e)  $4 - x = \frac{2(x+7)}{3}$

Level 7

N22 C26 C27 C28 C29 C30 C31 A16 A17 A18 A19 A20 A21 A22 A23 A24 A25  
A26 A27 A28 A29 S30 S31 S32 S33 S34 S35 S36 S37 D14 D15

# A20

## Rearranging a Formula

- 1) Rearrange to make  $x$  the subject of the formula
- $y = x - 2$
  - $y = x + 7$
  - $y = x + t$
  - $y = 5x + 3$
  - $y = 2x - 4$
- 2) Rearrange to make  $x$  the subject of the formula
- $3x + 2 = y$
  - $4x - 1 = y$
  - $ax - 3 = y$
  - $ax + m = t$
  - $x + y = t$
- 3) Rearrange to make  $x$  the subject of the formula
- $y = x + t - v$
  - $ax - c = y$
  - $y = ax - tv + c$
  - $y + x = ct$
  - $c + ax + t = y + m$
- 4) Rearrange to make  $x$  the subject of the formula
- $\frac{x+2}{3} = y$
  - $y = \frac{x-4}{5}$
  - $\frac{5x-2}{4} = y$
  - $\frac{ax+c}{m} = y$
  - $k = \frac{t+mx}{y}$
- 5) Rearrange to make  $x$  the subject of the formula
- $y = \frac{3x}{4}$
  - $y = \frac{2x}{5} - 8$
  - $y = \frac{cx}{t} + m$
  - $y = abx + c$
  - $\frac{mx}{t} + c = y$
- 6) Rearrange to make  $x$  the subject of the formula
- $y = 4(x + t)$
  - $y = a(x - m)$
  - $at(c + x) = y$
  - $y + m = a(c + x)$
  - $t - v = m(x - y)$
- 7) Rearrange to make  $x$  the subject of the formula
- $\frac{x-u}{4} = y$
  - $\frac{x+a}{b} = c$
  - $\frac{3(x+2)}{c} = y$
  - $\frac{a(x+b)}{c} = d$
  - $\frac{t(x+c)}{d} = e + f$

Level 7

[N22](#) [C26](#) [C27](#) [C28](#) [C29](#) [C30](#) [C31](#) [A16](#) [A17](#) [A18](#) [A19](#) [A20](#) [A21](#) [A22](#) [A23](#) [A24](#) [A25](#)  
[A26](#) [A27](#) [A28](#) [A29](#) [S30](#) [S31](#) [S32](#) [S33](#) [S34](#) [S35](#) [S36](#) [S37](#) [D14](#) [D15](#)

# A21

## Trial and Improvement

- 1) The equation  $x^2 + 3x = 37$   
has a solution between 4 and 5.  
Use a trial and improvement method to find this solution.  
Give your answer to one decimal place.  
You must show ALL your working.
  
- 2) The equation  $x^2 - 4x = 6$   
has a solution between 5 and 6.  
Use a trial and improvement method to find this solution.  
Give your answer to one decimal place.  
You must show ALL your working.

Level 7

[N22](#) [C26](#) [C27](#) [C28](#) [C29](#) [C30](#) [C31](#) [A16](#) [A17](#) [A18](#) [A19](#) [A20](#) [A21](#) [A22](#) [A23](#) [A24](#) [A25](#)  
[A26](#) [A27](#) [A28](#) [A29](#) [S30](#) [S31](#) [S32](#) [S33](#) [S34](#) [S35](#) [S36](#) [S37](#) [D14](#) [D15](#)



# A22

## Inequalities

1) Represent the inequalities on the number lines.

a)  $x \leq 3$

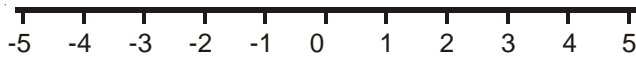

b)  $-1 < x \leq 4$

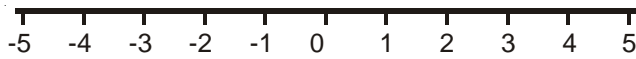

c)  $-3 \leq x \leq 3$



2) Write down the inequalities shown below

a)

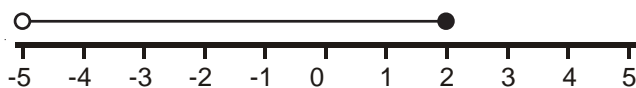

b)

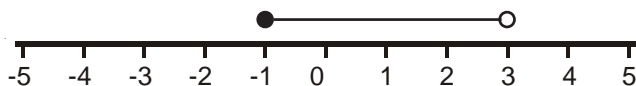

c)

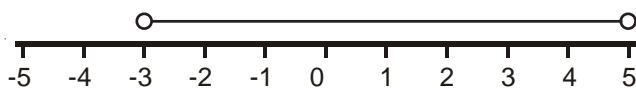

3) If  $x$  is an integer, what are the possible values of  $x$ ?

a)  $-4 \leq x \leq 2$

b)  $-3 \leq x < 1$

c)  $1 < x \leq 5$

d)  $-3 < x \leq 4$

e)  $-7 \leq x \leq -4$

Level 7

[N22](#) [C26](#) [C27](#) [C28](#) [C29](#) [C30](#) [C31](#) [A16](#) [A17](#) [A18](#) [A19](#) [A20](#) [A21](#) [A22](#) [A23](#) [A24](#) [A25](#)  
[A26](#) [A27](#) [A28](#) [A29](#) [S30](#) [S31](#) [S32](#) [S33](#) [S34](#) [S35](#) [S36](#) [S37](#) [D14](#) [D15](#)



# A23

## Solving Inequalities

1) Solve

- a)  $2x - 1 \geq 7$
- b)  $3x + 4 < 19$
- c)  $5x - 7 \leq 18$
- d)  $2x + 9 > 5$
- e)  $4x + 11 \leq 14$

2) Solve

- a)  $\frac{x}{3} < 7$
- b)  $\frac{x}{5} - 1 \geq 3$
- c)  $\frac{2x}{3} + 4 \leq 9$
- d)  $12 \geq 2x - 1$
- e)  $20 < 5 + 5x$

3) Solve

- a)  $2(5x - 1) \leq 18$
- b)  $3(4x + 2) > 60$
- c)  $42 > 2(6x + 15)$
- d)  $4(1 + x) \leq 12$
- e)  $8(2x - 1) > 12$

4) Solve

- a)  $2x + 7 \leq x + 9$
- b)  $x - 6 > 3x - 18$
- c)  $4x + 3 < 2x - 9$
- d)  $2x - 4 \geq 7x - 34$
- e)  $2(x + 3) < x - 1$

Level 7

[N22](#) [C26](#) [C27](#) [C28](#) [C29](#) [C30](#) [C31](#) [A16](#) [A17](#) [A18](#) [A19](#) [A20](#) [A21](#) [A22](#) [A23](#) [A24](#) [A25](#)  
[A26](#) [A27](#) [A28](#) [A29](#) [S30](#) [S31](#) [S32](#) [S33](#) [S34](#) [S35](#) [S36](#) [S37](#) [D14](#) [D15](#)

# A24

## Understanding Straight Line Graphs

- 1) Find the gradients of the lines A to F.

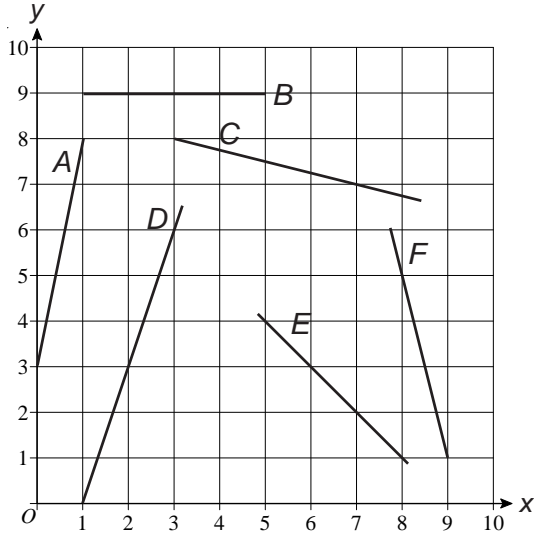

- 2) Find the gradients of the lines G to K.

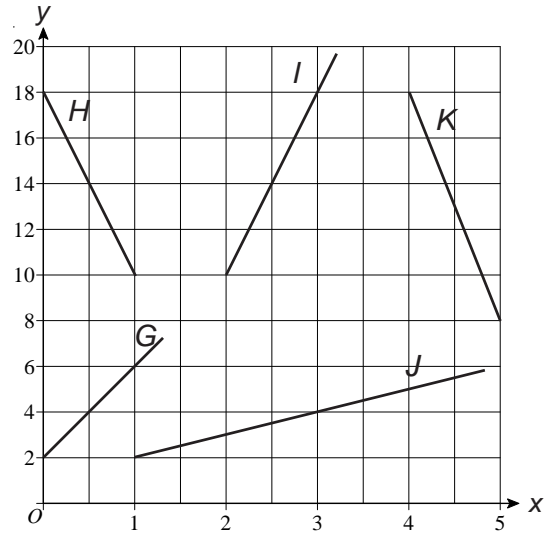

- 3) Find the equations of lines A and B.

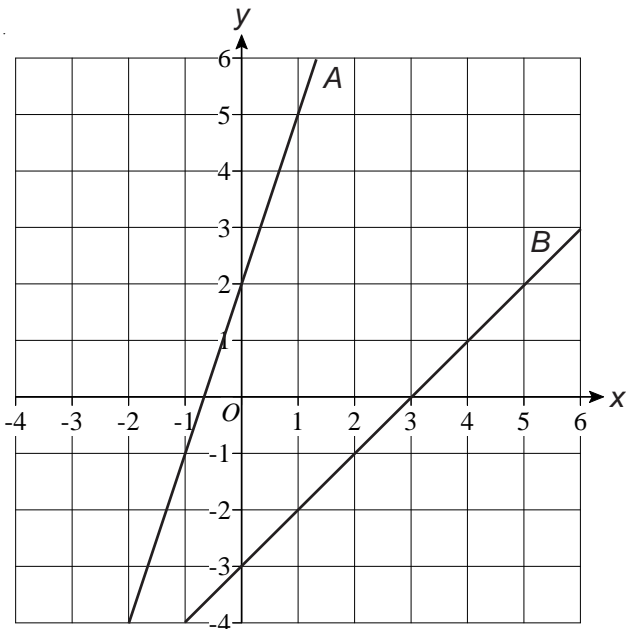

- 4) Find the equations of lines C, D and E.

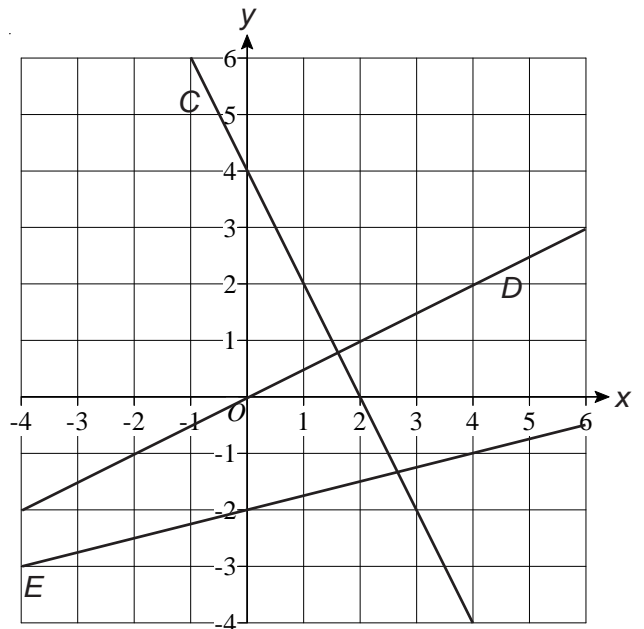

Level 7

[N22](#) [C26](#) [C27](#) [C28](#) [C29](#) [C30](#) [C31](#) [A16](#) [A17](#) [A18](#) [A19](#) [A20](#) [A21](#) [A22](#) [A23](#) [A24](#) [A25](#)  
[A26](#) [A27](#) [A28](#) [A29](#) [S30](#) [S31](#) [S32](#) [S33](#) [S34](#) [S35](#) [S36](#) [S37](#) [D14](#) [D15](#)

# A25

## Regions

- 1) a) Shade the region represented by  $x \leq -1$   
 b) Shade the region represented by  $x > 3$

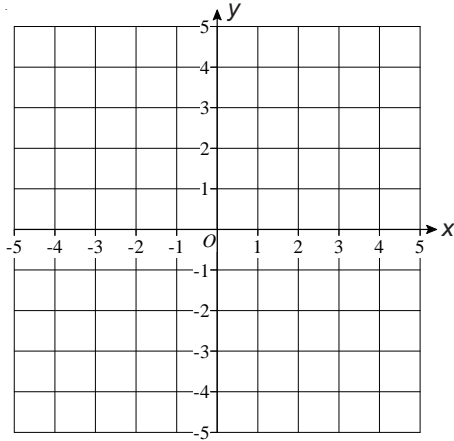

- 2) a) Shade the region represented by  $y < -1$   
 b) Shade the region represented by  $y \geq 2$

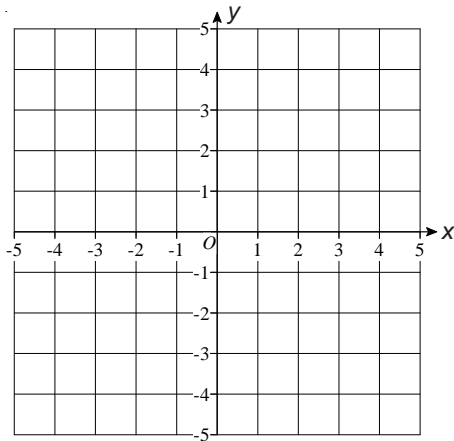

- 3) Shade the region represented by  $-3 \leq x < 2$

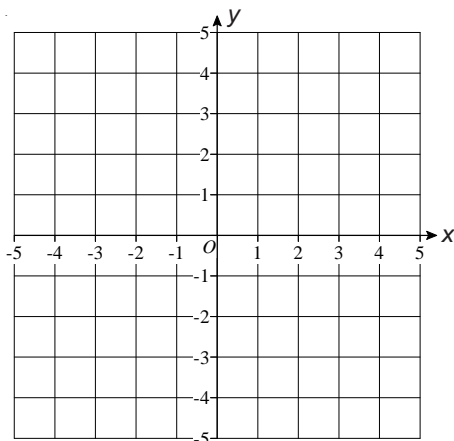

- 4) Shade the region represented by  $1 \leq y \leq 4$

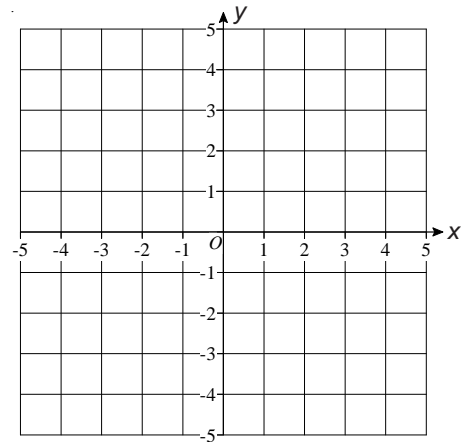

- 5) Shade the region where  $-1 \leq x \leq 3$   
 and  $-4 \leq y \leq -2$

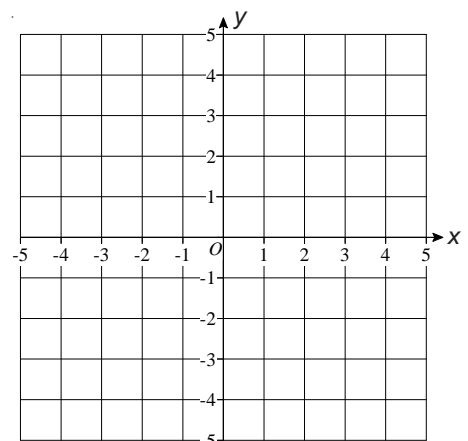

- 6) Shade the region where  $-3 < x < 2$   
 and  $-1 < y < 4$

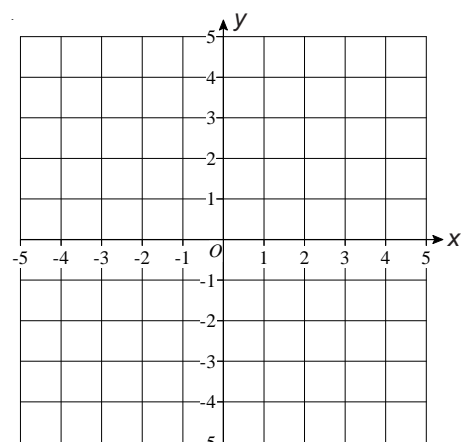

Level 7

[N22](#) [C26](#) [C27](#) [C28](#) [C29](#) [C30](#) [C31](#) [A16](#) [A17](#) [A18](#) [A19](#) [A20](#) [A21](#) [A22](#) [A23](#) [A24](#) [A25](#)  
[A26](#) [A27](#) [A28](#) [A29](#) [S30](#) [S31](#) [S32](#) [S33](#) [S34](#) [S35](#) [S36](#) [S37](#) [D14](#) [D15](#)

# A26

## Simultaneous Equations Graphically

- 1)
  - a) Complete the table of values for  $y = x + 2$
  - b) Draw the graph of  $y = x + 2$
  - c) Complete the table of values for  $x + y = 7$
  - d) Draw the graph of  $x + y = 7$
  - e) Use your graph to solve the simultaneous equations  $y = x + 2$  and  $x + y = 7$

x	0	1	2	3	4
y					

x	0	1	2	3	4
y					

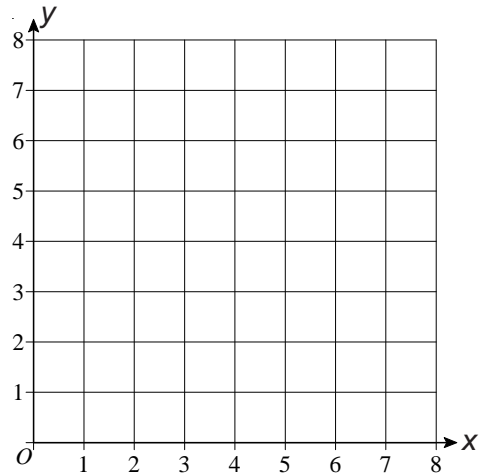

- 2) Using a graphical method, solve the simultaneous equations

$$y = 2x - 3 \text{ and } y = 6 - x$$

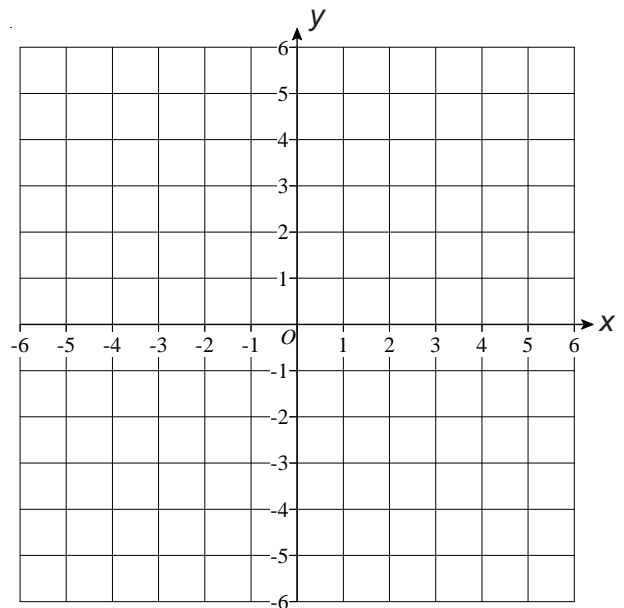

- 3) Solve the simultaneous equations  $y = x + 6$  and  $y = 3 - x$
- 4) Solve the simultaneous equations  $y = x - 14$  and  $y = 2 - 3x$

### Level 7

[N22](#) [C26](#) [C27](#) [C28](#) [C29](#) [C30](#) [C31](#) [A16](#) [A17](#) [A18](#) [A19](#) [A20](#) [A21](#) [A22](#) [A23](#) [A24](#) [A25](#)  
[A26](#) [A27](#) [A28](#) [A29](#) [S30](#) [S31](#) [S32](#) [S33](#) [S34](#) [S35](#) [S36](#) [S37](#) [D14](#) [D15](#)

# A27

## Simultaneous Equations Algebraically

- 1) Solve  $3x + y = 11$   
 $4x - y = 3$
- 2) Solve  $2x - 5y = 3$   
 $4x + 5y = 21$
- 3) Solve  $x - 2y = 3$   
 $3x + 2y = 5$
- 4) Solve  $x + 3y = 10$   
 $x + y = 6$
- 5) Solve  $3x + 2y = 3$   
 $2x + 2y = 5$
- 6) Solve  $5x - 3y = 23$   
 $2x - 3y = 11$
- 7) Solve  $3x - 2y = 6$   
 $x + y = 7$
- 8) Solve  $6x + y = 10$   
 $2x - 3y = 10$
- 9) Solve  $2x + 7y = 11$   
 $3x - 2y = 4$
- 10) Solve  $4x + 3y = 9$   
 $5x + 2y = 13$
- 11) Solve  $2x + 3y = -7$   
 $7x - 2y = -12$
- 12) Solve  $3x - 2y = 5$   
 $9x + 5y = -7$
- 13) In the first week of opening, a zoo sold 200 adult tickets and 300 child tickets. The takings for that week were £2600.  
In the second week, 500 adult tickets were sold and 400 child tickets were sold. The takings for the second week were £5100.  
Form two equations and solve them to find the price of an adult ticket and the price of a child ticket.
- 14) If you multiply Sid's age by four and Tony's age by five and add the answers together it comes to 259 years.  
However, if you multiply Sid's age by seven and then take away two times Tony's age the answer is 120 years.  
Form two equations and solve them to find the ages of Sid and Tony.
- 15) If nine rats and seven ferrets cost £116.75 and four rats and six ferrets cost £88, how much would five rats and four ferrets cost?
- 16) If a mouse and a goldfish cost £1.10 and the mouse costs £1 more than the goldfish, how much does the goldfish cost?

Level 7

[N22](#) [C26](#) [C27](#) [C28](#) [C29](#) [C30](#) [C31](#) [A16](#) [A17](#) [A18](#) [A19](#) [A20](#) [A21](#) [A22](#) [A23](#) [A24](#) [A25](#)  
[A26](#) [A27](#) [A28](#) [A29](#) [S30](#) [S31](#) [S32](#) [S33](#) [S34](#) [S35](#) [S36](#) [S37](#) [D14](#) [D15](#)

# A28

## $n$ th Term of Quadratic Sequences

- 1) Find the  $n$ th term of
  - a) 1, 4, 9, 16, 25, . . . . .
  - b) 2, 5, 10, 17, 26, . . . . .
  - c) 0, 3, 8, 15, 24, . . . . .
  
- 2) Find the  $n$ th term of
  - a) 1, 4, 9, 16, 25, . . . . .
  - b) 2, 8, 18, 32, 50, . . . . .
  - c) 0.5, 2, 4.5, 8, 12.5, . . . . .
  
- 3) Find the  $n$ th term of
  - a) 3, 9, 19, 33, 51, . . . . .
  - b) 1, 7, 17, 31, 49, . . . . .
  - c) 11, 41, 91, 161, 251, . . . . .
  
- 4) For the following  $n$ th terms, find the first three terms and the tenth term
  - a)  $n^2 + 4$
  - b)  $n^2 - 3$
  - c)  $n^2 + 10$
  - d)  $n^2 + 2n$
  - e)  $n^2 - n$
  
- 5) For the following  $n$ th terms, find the first three terms and the tenth term
  - a)  $4n^2$
  - b)  $2n^2 + 3n$
  - c)  $3n^2 - 2n$
  - d)  $n^2 + n + 1$
  - e)  $2n^2 + 4n - 3$

### Level 7

[N22](#) [C26](#) [C27](#) [C28](#) [C29](#) [C30](#) [C31](#) [A16](#) [A17](#) [A18](#) [A19](#) [A20](#) [A21](#) [A22](#) [A23](#) [A24](#) [A25](#)  
[A26](#) [A27](#) [A28](#) [A29](#) [S30](#) [S31](#) [S32](#) [S33](#) [S34](#) [S35](#) [S36](#) [S37](#) [D14](#) [D15](#)

# A29

## Graphs of Quadratic and Cubic Functions

1) a) Complete the table of values for  $y = x^2 - 2$

x	-2	-1	0	1	2	3
y		-1			2	

b) Draw the graph of  $y = x^2 - 2$

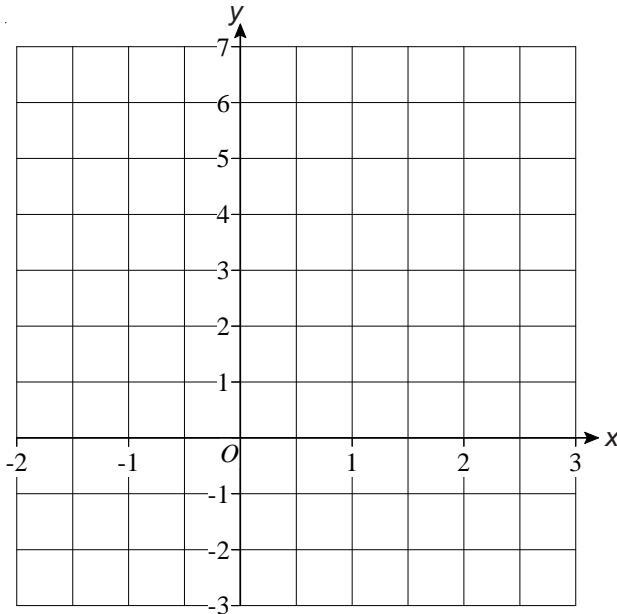

c) Use the graph to estimate the values of  $x$  when  $y = 1$

2) a) Complete the table of values for  $y = 4x^2$

x	-2	-1	0	1	2
y		4			16

b) Draw the graph of  $y = 4x^2$

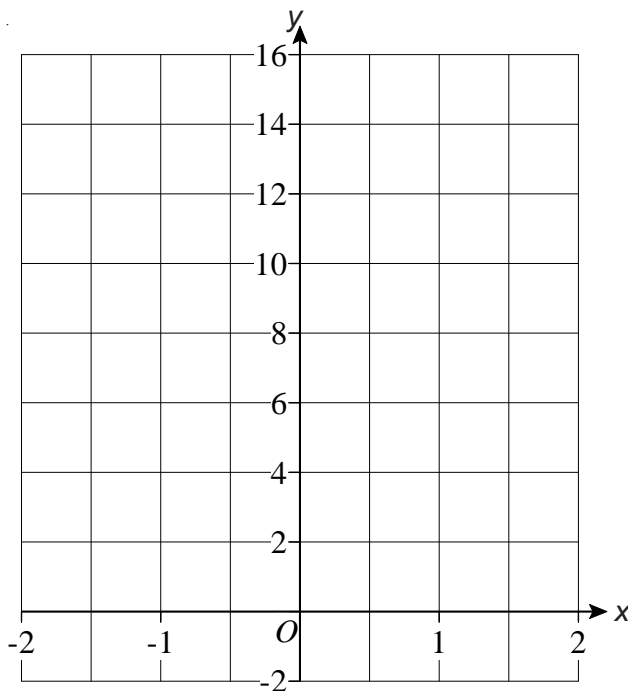

c) Use the graph to estimate the value of  $y$  when  $x = 1.5$

Level 7

[N22](#) [C26](#) [C27](#) [C28](#) [C29](#) [C30](#) [C31](#) [A16](#) [A17](#) [A18](#) [A19](#) [A20](#) [A21](#) [A22](#) [A23](#) [A24](#) [A25](#)  
[A26](#) [A27](#) [A28](#) [A29](#) [S30](#) [S31](#) [S32](#) [S33](#) [S34](#) [S35](#) [S36](#) [S37](#) [D14](#) [D15](#)

# A29

## Graphs of Quadratic and Cubic Functions

1) a) Complete the table of values for  $y = x^2 + 2x$

x	-2	-1	0	1	2	3
y		-1			8	

b) Draw the graph of  $y = x^2 + 2x$

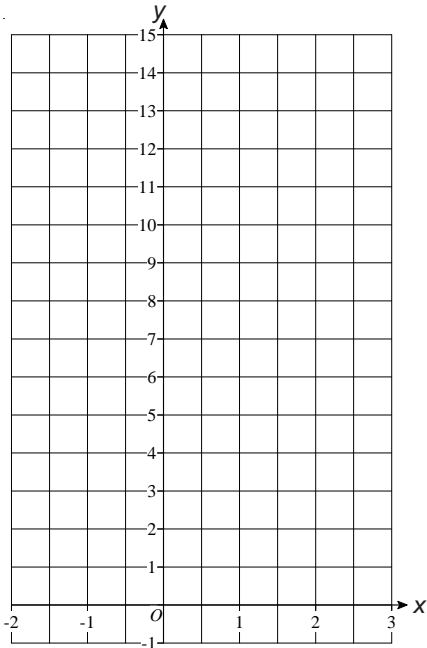

c) Use the graph to estimate the values of  $x$  when  $y = -0.5$

2) a) Complete the table of values for  $y = x^2 - 2x + 1$

x	-2	-1	0	1	2	3
y		4			1	

b) Draw the graph of  $y = x^2 - 2x + 1$

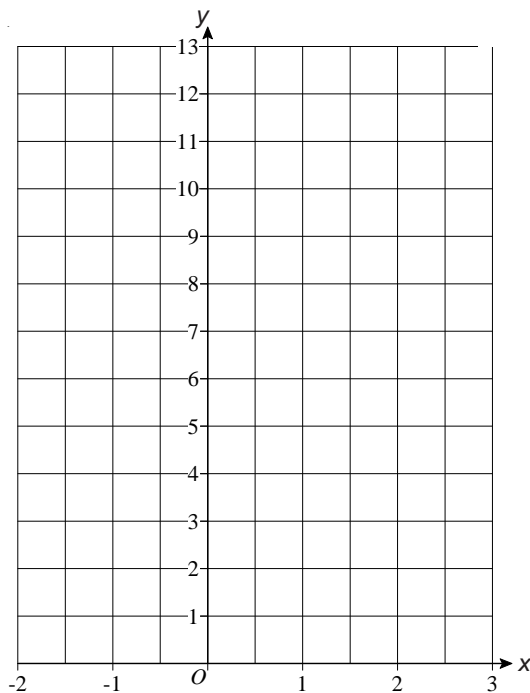

c) Use the graph to estimate the value of  $y$  when  $x = 2.5$

Level 7

[N22](#) [C26](#) [C27](#) [C28](#) [C29](#) [C30](#) [C31](#) [A16](#) [A17](#) [A18](#) [A19](#) [A20](#) [A21](#) [A22](#) [A23](#) [A24](#) [A25](#)  
[A26](#) [A27](#) [A28](#) [A29](#) [S30](#) [S31](#) [S32](#) [S33](#) [S34](#) [S35](#) [S36](#) [S37](#) [D14](#) [D15](#)



# A29

## Graphs of Quadratic and Cubic Functions

1) a) Complete the table of values for  $y = 2x^2 + 2x - 3$

x	-2	-1	0	1	2
y		-3			9

b) Draw the graph of  $y = 2x^2 + 2x - 3$

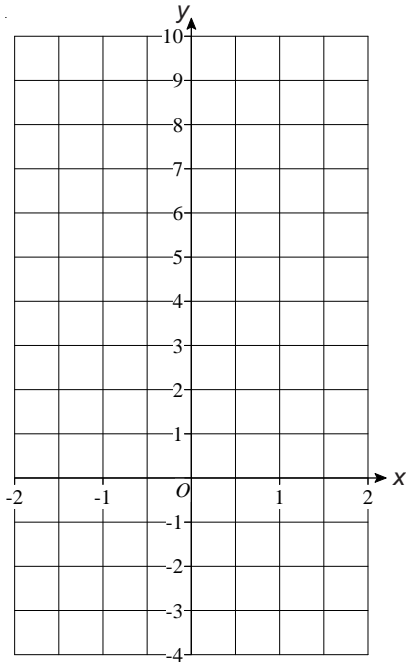

c) Use the graph to estimate the values of  $x$  when  $y = -2$

2) a) Complete the table of values for  $y = x^3 + x$

x	-2	-1	0	1	2
y		-2			10

b) Draw the graph of  $y = x^3 + x$

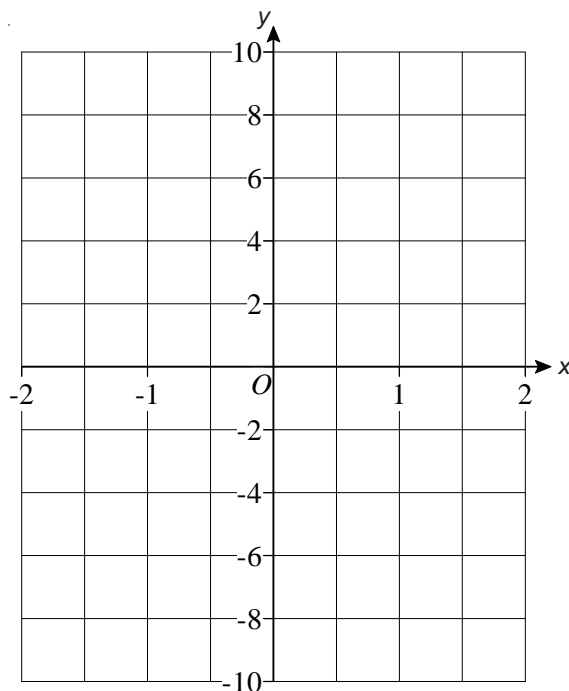

Level 7

[N22](#) [C26](#) [C27](#) [C28](#) [C29](#) [C30](#) [C31](#) [A16](#) [A17](#) [A18](#) [A19](#) [A20](#) [A21](#) [A22](#) [A23](#) [A24](#) [A25](#)  
[A26](#) [A27](#) [A28](#) [A29](#) [S30](#) [S31](#) [S32](#) [S33](#) [S34](#) [S35](#) [S36](#) [S37](#) [D14](#) [D15](#)

# S30

## Pythagoras' Theorem

1) Use Pythagoras' theorem to work out the areas of squares *A* and *B*.

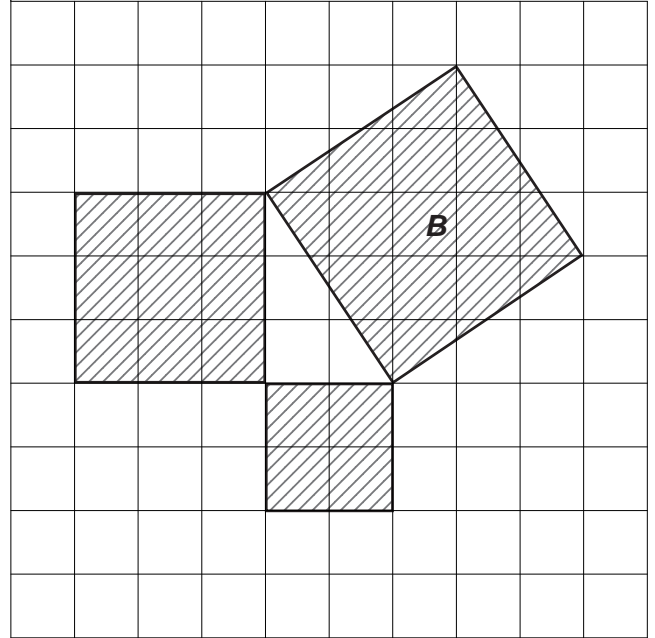
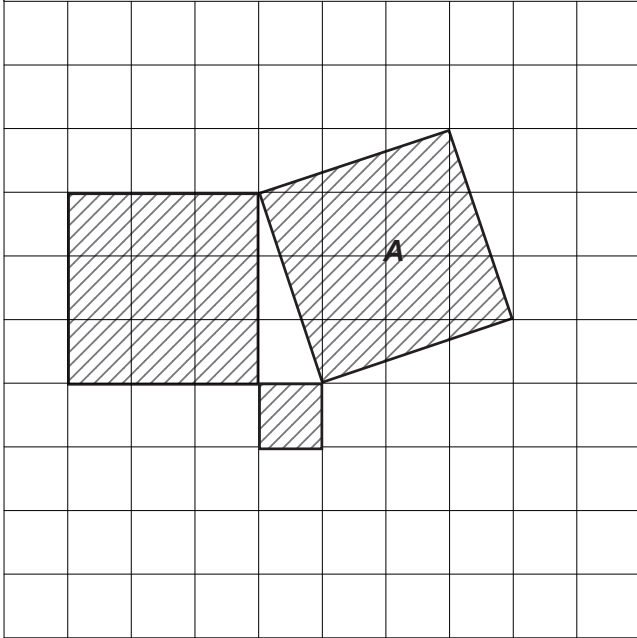

2) Use Pythagoras' theorem to work out the areas of squares *C* and *D*.

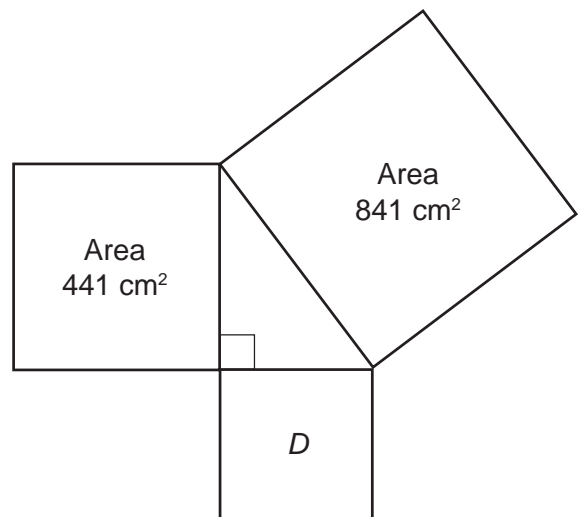
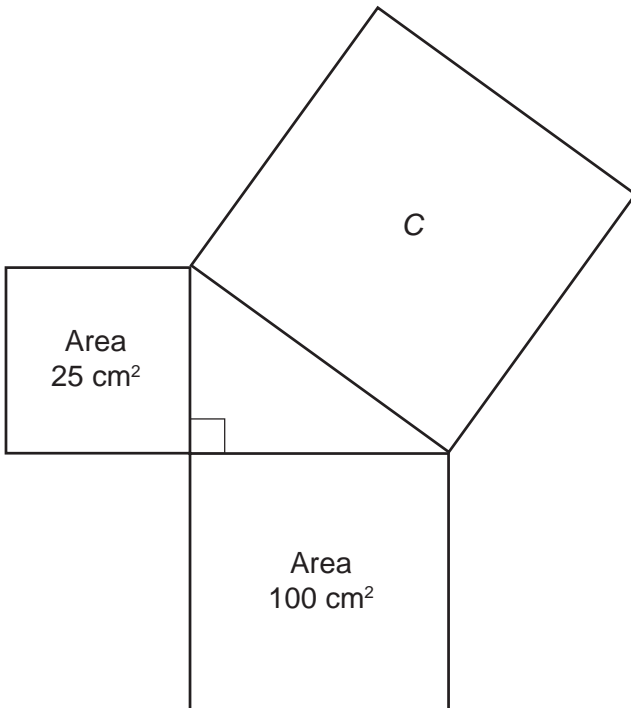

Level 7

[N22](#) [C26](#) [C27](#) [C28](#) [C29](#) [C30](#) [C31](#) [A16](#) [A17](#) [A18](#) [A19](#) [A20](#) [A21](#) [A22](#) [A23](#) [A24](#) [A25](#)  
[A26](#) [A27](#) [A28](#) [A29](#) [S30](#) [S31](#) [S32](#) [S33](#) [S34](#) [S35](#) [S36](#) [S37](#) [D14](#) [D15](#)

# S30

## Pythagoras' Theorem

1) Find the lengths of the sides of these three squares.

a)



b)

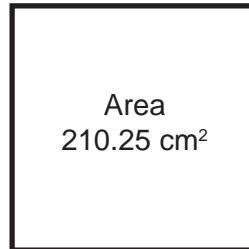

c)

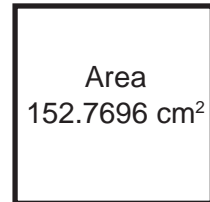

2) Find the lengths of the sides labelled *a* to *d*.

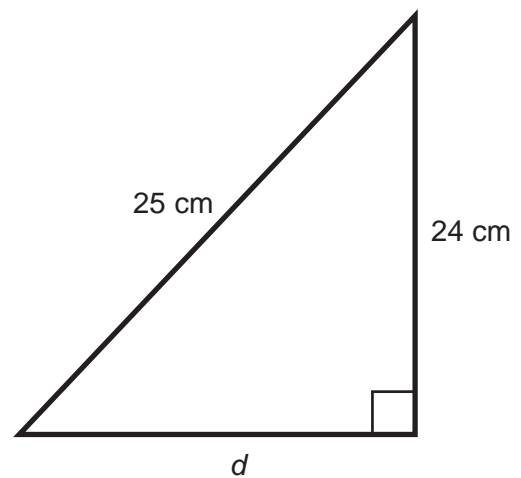
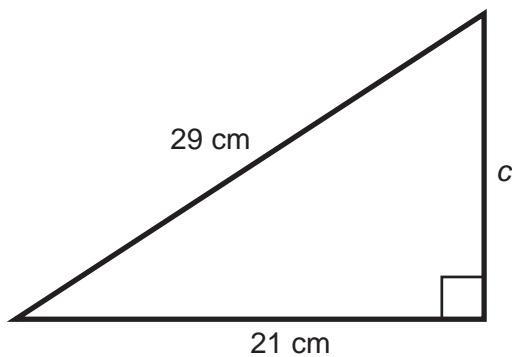
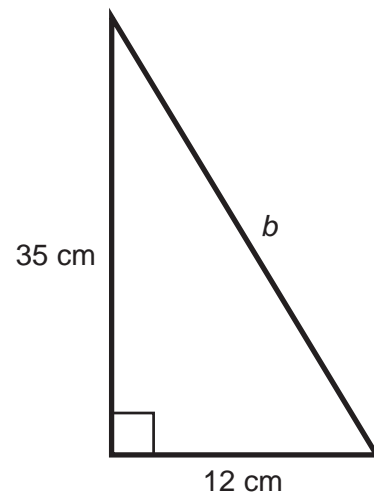
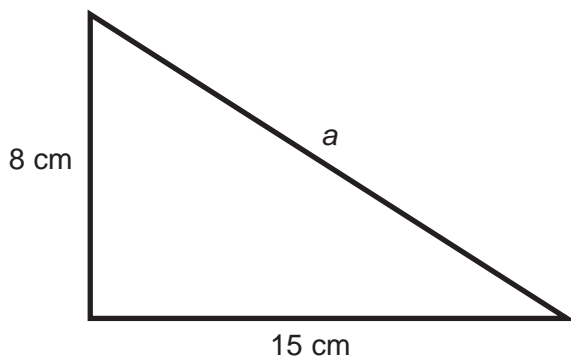

Level 7

N22 C26 C27 C28 C29 C30 C31 A16 A17 A18 A19 A20 A21 A22 A23 A24 A25  
A26 A27 A28 A29 S30 S31 S32 S33 S34 S35 S36 S37 D14 D15

# S30

## Pythagoras' Theorem

1) Calculate the lengths of the sides  $a$  to  $f$ , giving each answer to 1 decimal place.

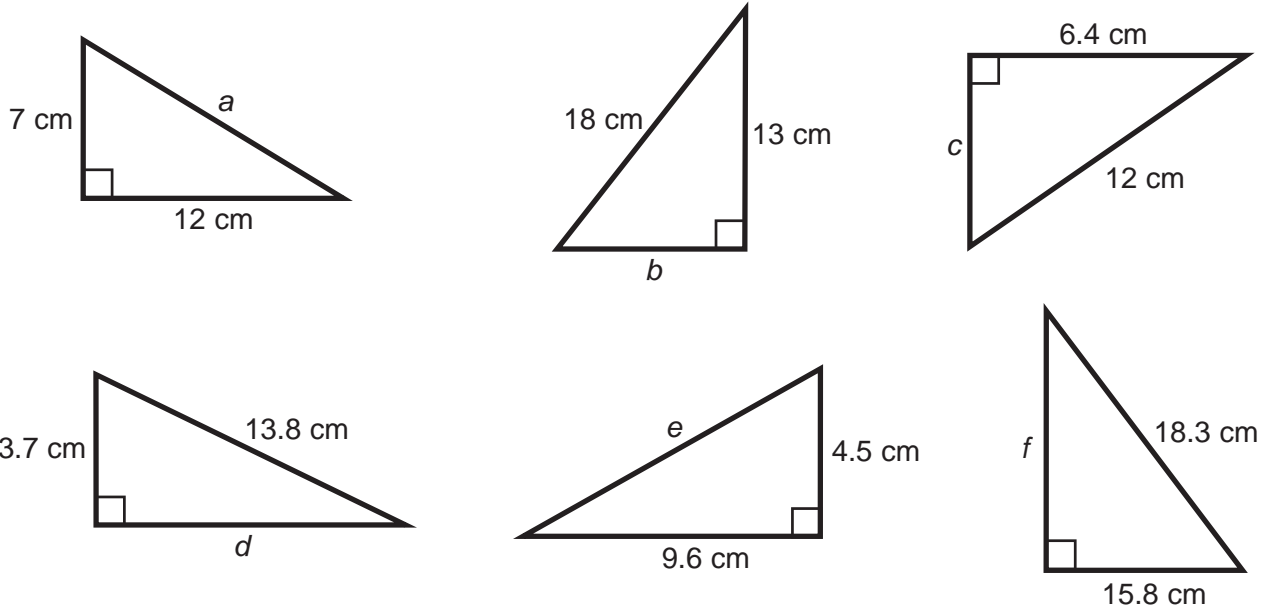

2) Calculate the lengths of the sides  $a$  and  $b$ , giving each answer to 1 decimal place.

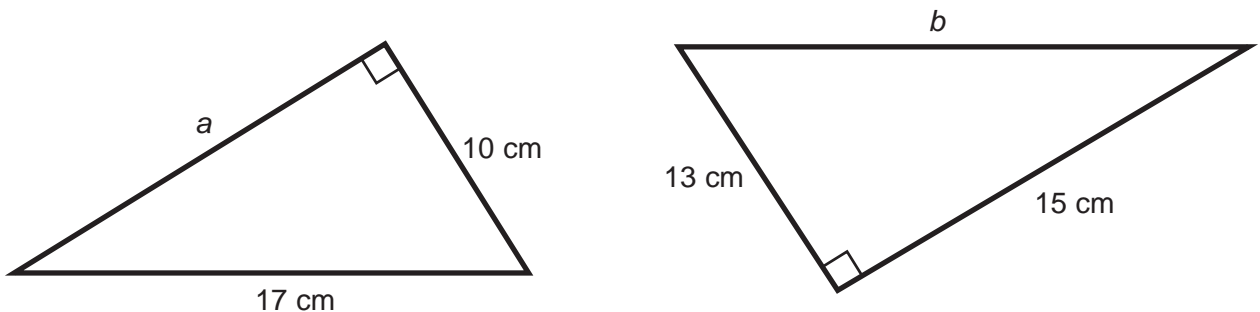

3) Find the height of this isosceles triangle. Give your answer to 1 decimal place.

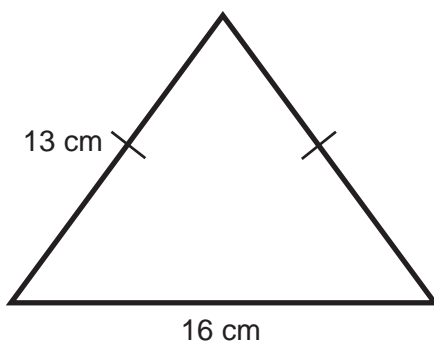

4) Find the area of this isosceles triangle.

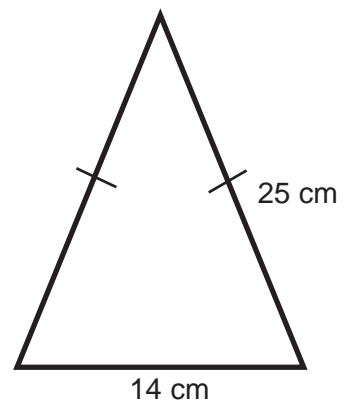

Level 7

N22 C26 C27 C28 C29 C30 C31 A16 A17 A18 A19 A20 A21 A22 A23 A24 A25  
 A26 A27 A28 A29 S30 S31 S32 S33 S34 S35 S36 S37 D14 D15

# S31

## Areas of Compound Shapes

1) Find the areas of the following shapes:

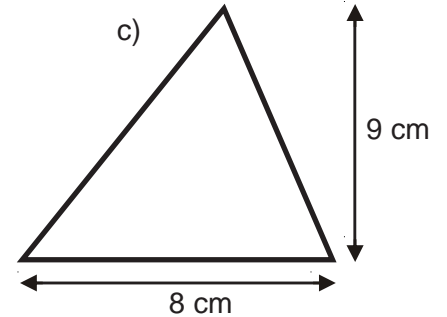
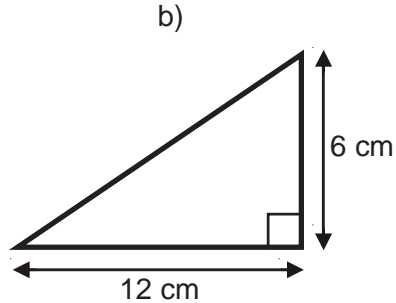
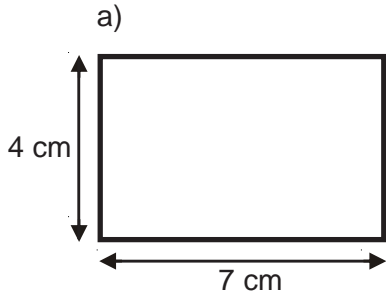

d) Take  $\pi$  to be 3.142

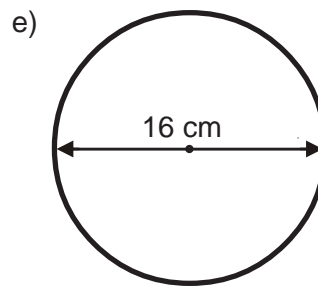
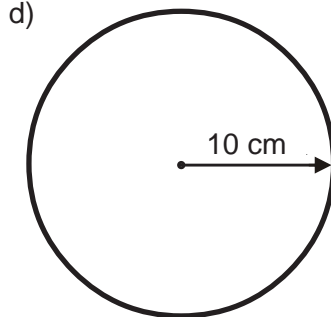

2) Find the areas of the following shapes:

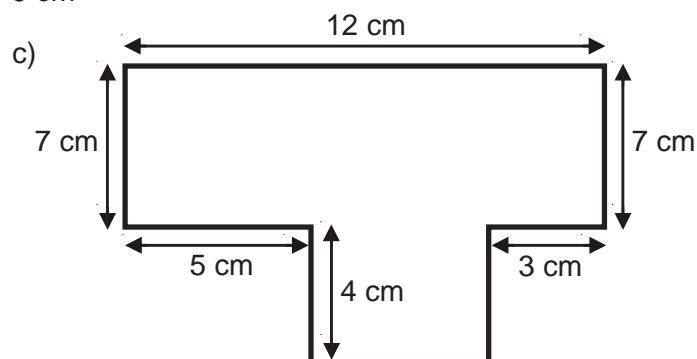
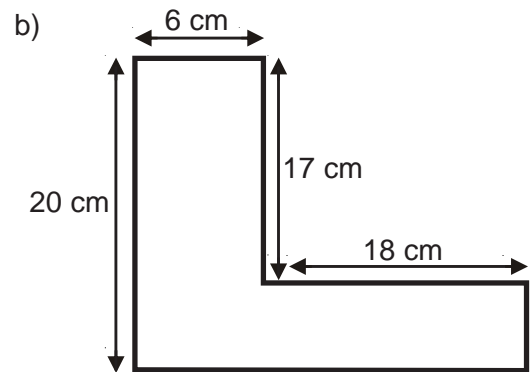
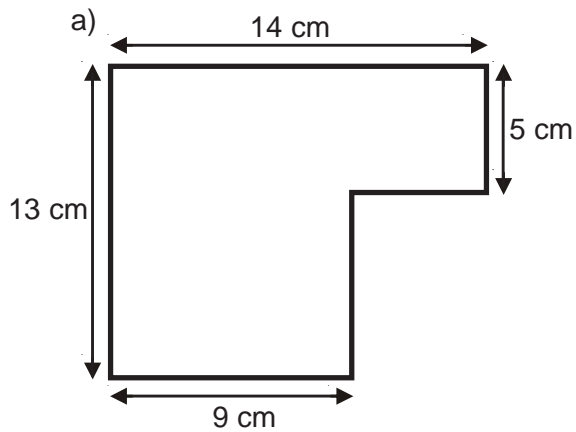

Level 7

# S31

## Areas of Compound Shapes

1) Find the areas of the following shapes:

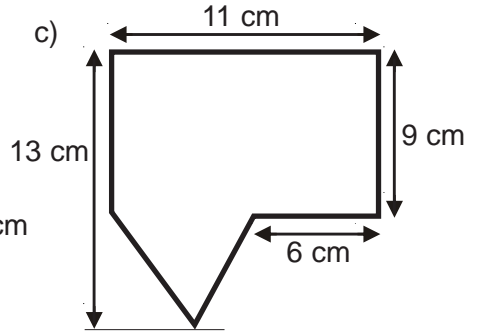
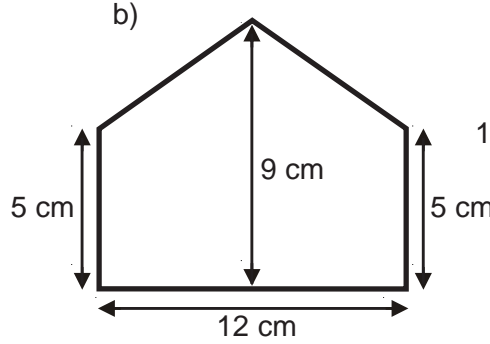
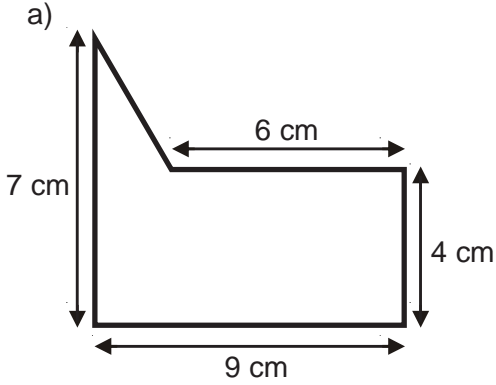

2) Find the areas of the shaded parts of the following:  
Take  $\pi$  to be 3.142 when needed.

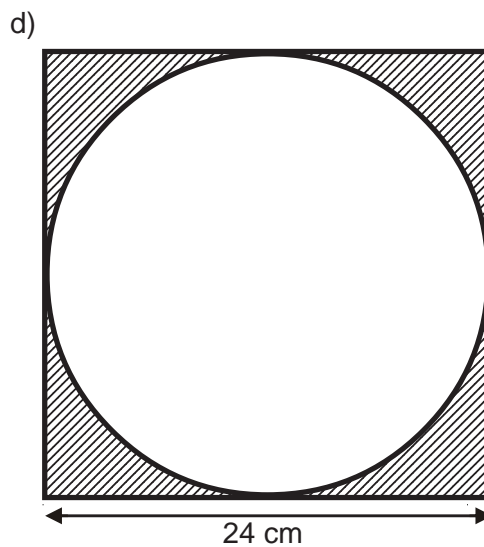
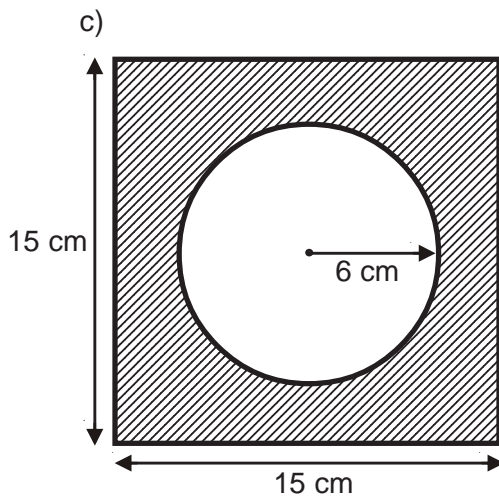
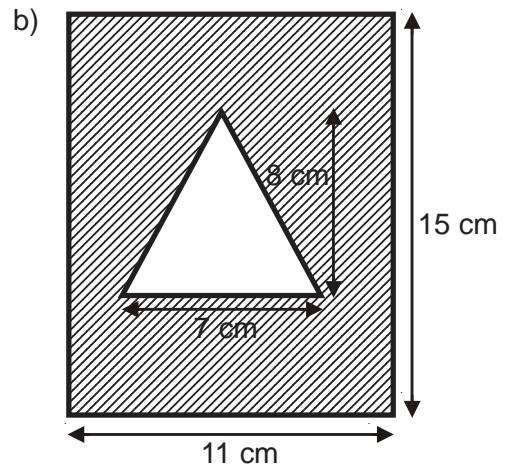
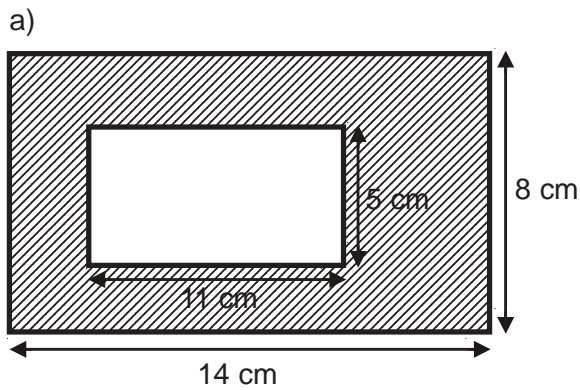

Level 7

# S31

## Areas of Compound Shapes

Find the areas of the shapes below:  
Take  $\pi$  to be 3.142

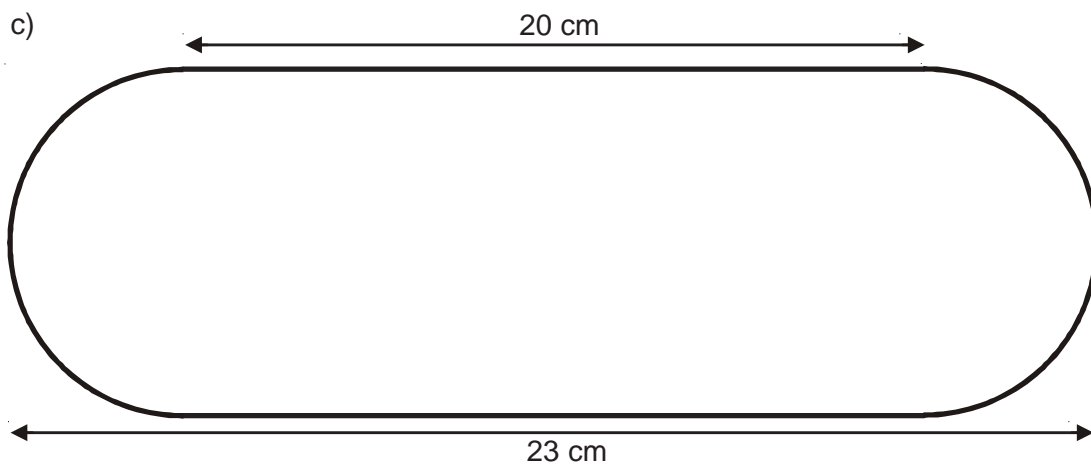
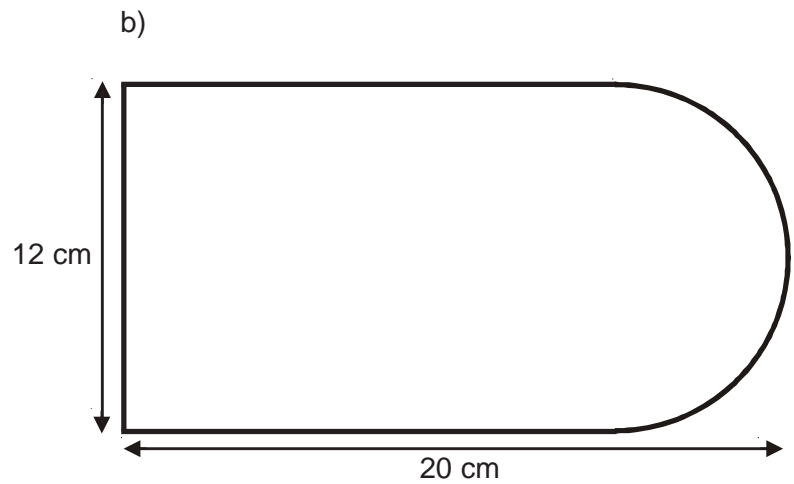
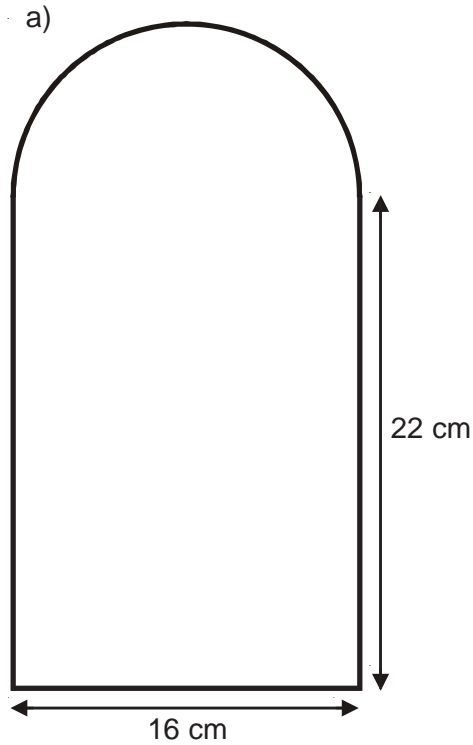

Level 7

N22 C26 C27 C28 C29 C30 C31 A16 A17 A18 A19 A20 A21 A22 A23 A24 A25  
A26 A27 A28 A29 S30 S31 S32 S33 S34 S35 S36 S37 D14 D15

# S32

## Volumes of Prisms

Find the volumes of the prisms, below.  
Take  $\pi$  to be 3.142 for questions c and d.

a)

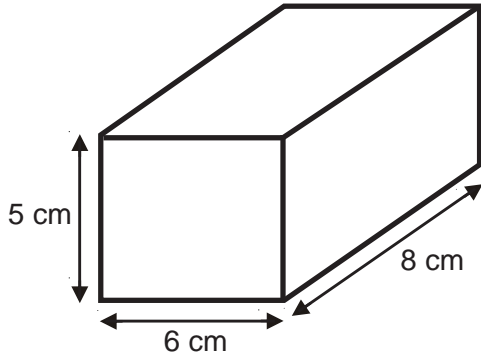

b)

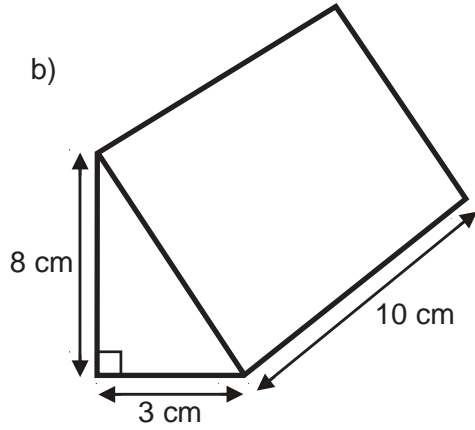

c)

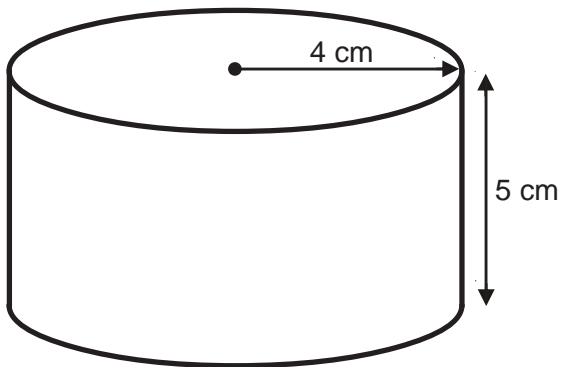

d)

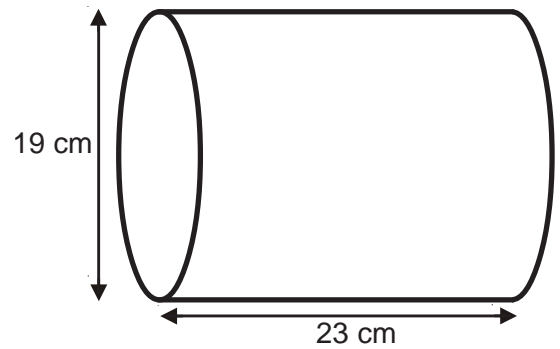

e)

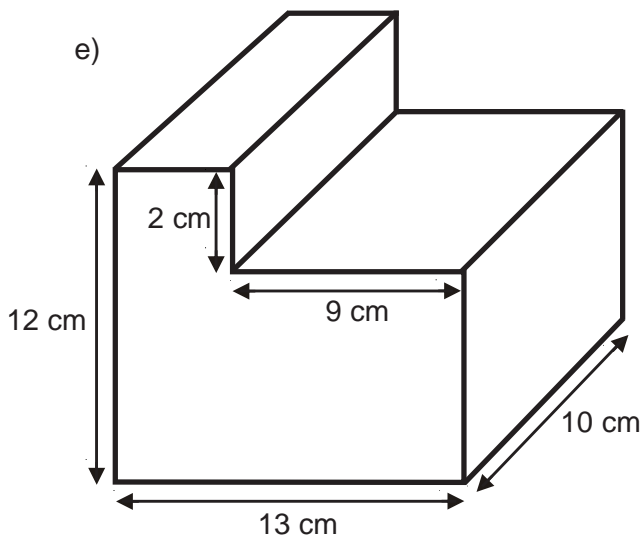

f)

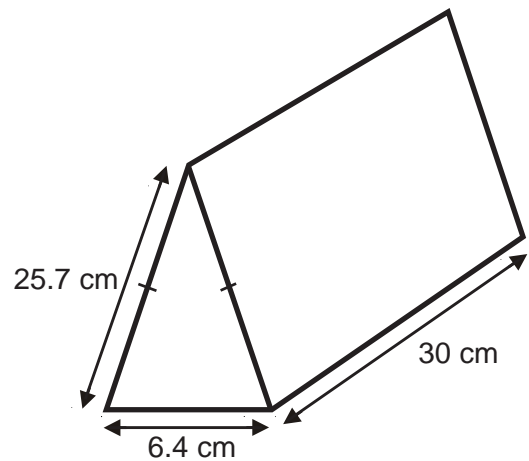

Level 7

N22 C26 C27 C28 C29 C30 C31 A16 A17 A18 A19 A20 A21 A22 A23 A24 A25  
A26 A27 A28 A29 S30 S31 S32 S33 S34 S35 S36 S37 D14 D15



# S33

## Surface Area of Triangular Prisms

- 1) Find the total surface area of this triangular prism.

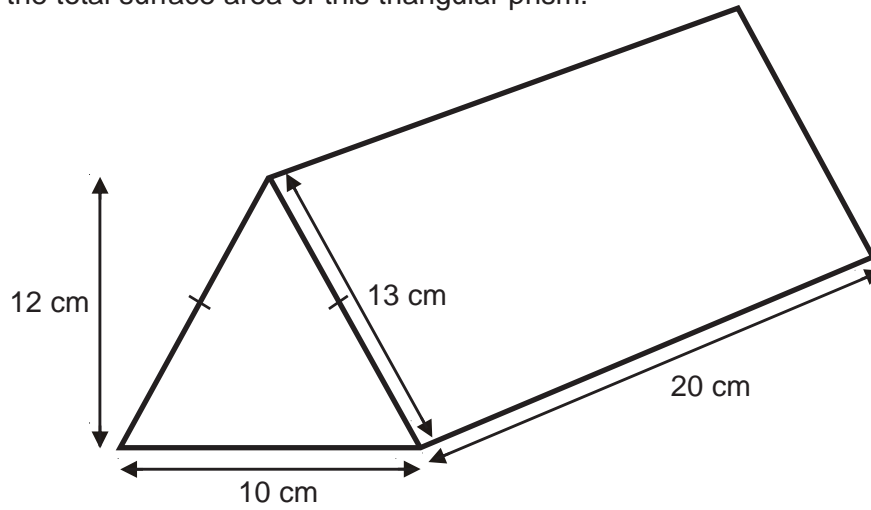

- 2) Find the total surface area of this triangular prism.

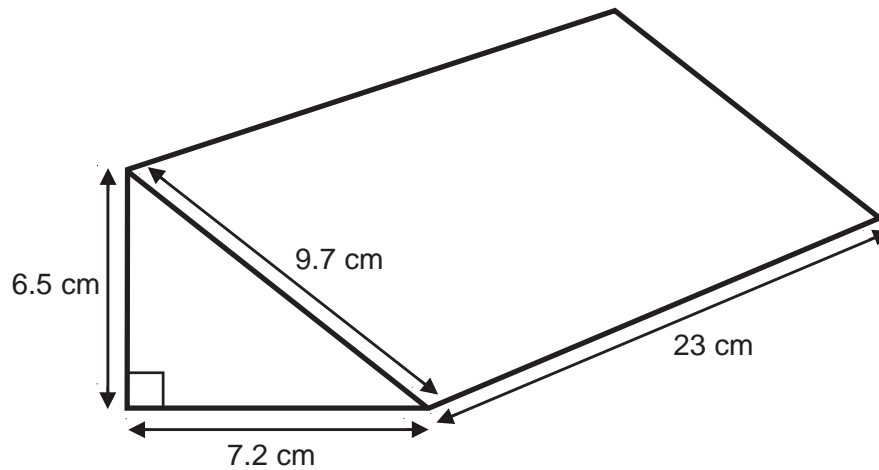

- 3) Find the total surface area of this triangular prism.  
You will need to use Pythagoras' theorem at some stage to get the answer.

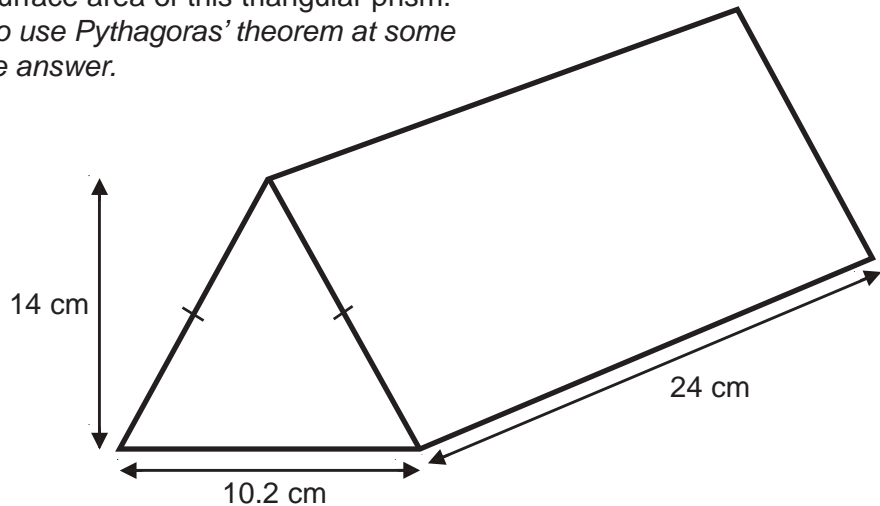

Level 7

N22 C26 C27 C28 C29 C30 C31 A16 A17 A18 A19 A20 A21 A22 A23 A24 A25  
A26 A27 A28 A29 S30 S31 S32 S33 S34 S35 S36 S37 D14 D15

# S34

## Loci

- 1) Draw the locus of all the points that are 1.2 cm away from the line  $AB$ .



- 2) Draw the locus of all the points that are 1.5 cm away from the rectangle  $ABCD$ .



- 3) Radio signals can be heard within a 4.5 km radius of transmitter  $A$  and a 5.5 km radius of transmitter  $B$ . Show, by shading, the area where radio signals can be heard from both transmitters at the same time. Use a scale of 1 cm represents 1 km.



Level 7

N22	C26	C27	C28	C29	C30	C31	A16	A17	A18	A19	A20	A21	A22	A23	A24	A25
A26	A27	A28	A29	S30	S31	S32	S33	S34	S35	S36	S37	D14	D15			

# S35

## Enlargement by a Negative Scale Factor

- 1) Enlarge line  $AB$  with scale factor  $-2$  and point  $(7, 6)$  as the centre of enlargement.

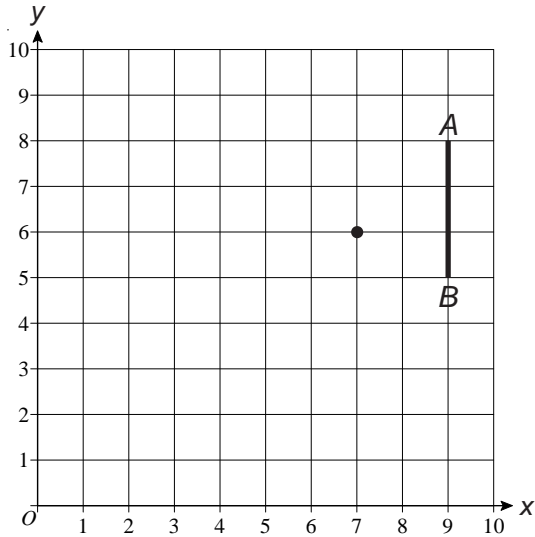

- 2) Enlarge line  $AB$  with scale factor  $-3$  and point  $(3, 4)$  as the centre of enlargement.

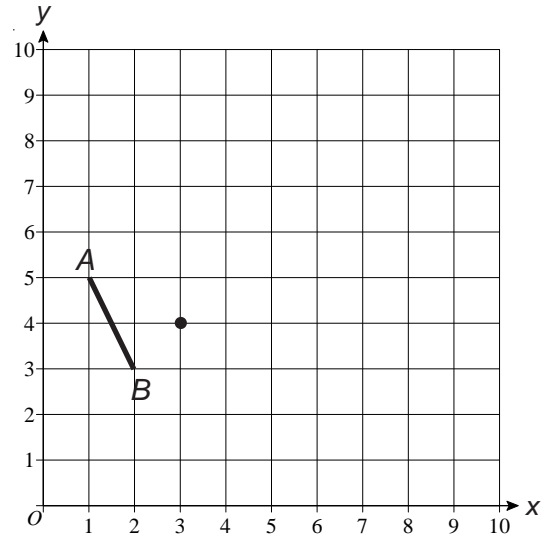

- 3) Enlarge triangle  $ABC$  with scale factor  $-2$  and point  $(7, 6)$  as the centre of enlargement.

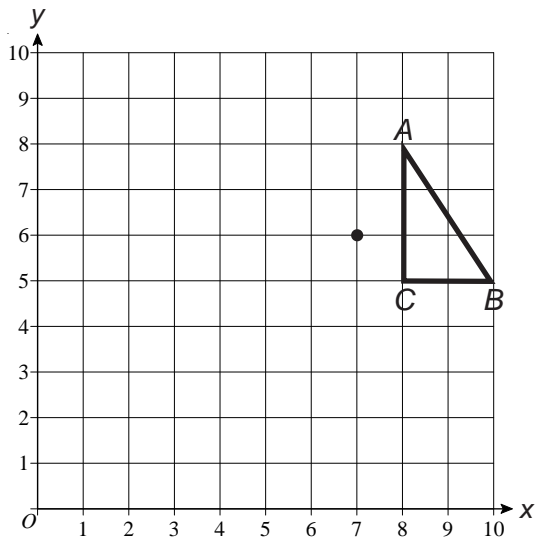

- 4) Enlarge triangle  $ABC$  with scale factor  $-1.5$  and point  $(4, 5)$  as the centre of enlargement.

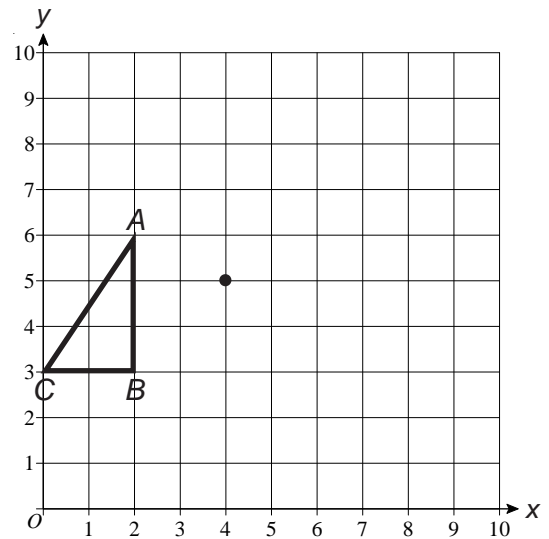

Level 7

[N22](#) [C26](#) [C27](#) [C28](#) [C29](#) [C30](#) [C31](#) [A16](#) [A17](#) [A18](#) [A19](#) [A20](#) [A21](#) [A22](#) [A23](#) [A24](#) [A25](#)  
[A26](#) [A27](#) [A28](#) [A29](#) [S30](#) [S31](#) [S32](#) [S33](#) [S34](#) [S35](#) [S36](#) [S37](#) [D14](#) [D15](#)

- 1) The length of a bracelet is 24 cm measured to the nearest centimetre.
  - a) Work out the lower bound of the length of the bracelet.
  - b) Work out the upper bound of the length of the bracelet.
  
- 2) The length of a snake is 80 cm measured to the nearest 10 centimetres.
  - a) Work out the lower bound of the length of the snake.
  - b) Work out the upper bound of the length of the snake.
  
- 3) The weight of a necklace is 145 g measured to the nearest 5 grams.
  - a) Work out the lower bound of the weight of the necklace.
  - b) Work out the upper bound of the weight of the necklace.
  
- 4) The length of a line is given as 17.2 cm measured to the nearest tenth of a centimetre.
  - a) Work out the lower bound of the length of the line.
  - b) Work out the upper bound of the length of the line.
  
- 5) A rectangle has a length of 80 cm and a width of 60 cm, both measured to the nearest 10 cm.
  - a) Work out the lower bound of the area of the rectangle.
  - b) Work out the upper bound of the perimeter of the rectangle.
  
- 6) A right-angled triangle has lengths as shown, all measured to the nearest centimetre.
  - a) Work out the lower bound of the area of the triangle.
  - b) Work out the upper bound of the area of the triangle.

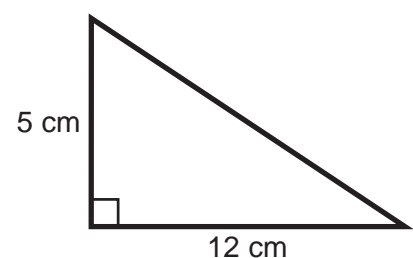
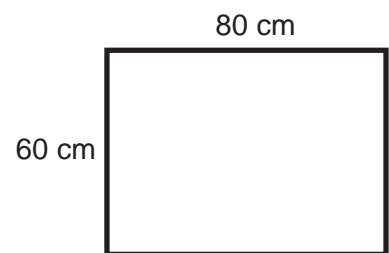

## Level 7

[N22](#) [C26](#) [C27](#) [C28](#) [C29](#) [C30](#) [C31](#) [A16](#) [A17](#) [A18](#) [A19](#) [A20](#) [A21](#) [A22](#) [A23](#) [A24](#) [A25](#)  
[A26](#) [A27](#) [A28](#) [A29](#) [S30](#) [S31](#) [S32](#) [S33](#) [S34](#) [S35](#) [S36](#) [S37](#) [D14](#) [D15](#)

# S37

## Compound Measures

- 1) A car travels at 60 mph for 3 hours.  
How far does the car travel?
- 2) A cyclist cycles for 4 hours and covers a distance of 48 miles.  
What was her average speed in miles per hour?
- 3) How long would it take a train which travels at an average speed of 80 mph to cover a distance of 400 miles?
- 4) A runner runs at a speed of 12 km/h for 3 hours and 15 minutes.  
How far does he run?
- 5) An aeroplane flies at an average speed of 510 mph.  
How long would it take to fly a distance of 2720 miles?
- 6) If a worm travels a distance of 8.25 m in 2 hours and 45 minutes, work out his average speed in metres per hour.
- 7) 12.5 cm<sup>3</sup> of mercury has a mass of 170 g.  
Work out the density of mercury.
- 8) Platinum has a density of 21.4 g/cm<sup>3</sup>.  
What is the mass of 35 cm<sup>3</sup> of platinum?
- 9) A quantity of ice had a mass of 62.56 g.  
Knowing that ice has a density of 0.92 g/cm<sup>3</sup>, work out how much ice there was, in cm<sup>3</sup>.
- 10) 15000 cm<sup>3</sup> of nitrogen has a mass of 18.765 g.  
Work out the density of nitrogen in g/cm<sup>3</sup>.
- 11) 15000 cm<sup>3</sup> of gold has a mass of 289.5 kg.  
Work out the density of gold in g/cm<sup>3</sup>.

### Level 7

N22 C26 C27 C28 C29 C30 C31 A16 A17 A18 A19 A20 A21 A22 A23 A24 A25  
A26 A27 A28 A29 S30 S31 S32 S33 S34 S35 S36 S37 D14 D15

# D14

## Averages from Tables

- 1) Sally conducted a survey to see how many sandwiches each pupil brought to school in her class per day. The results can be seen in the table.

No. of sandwiches	Frequency
0	1
1	5
2	6
3	12
4	2

- a) What is the modal number of sandwiches brought to school?  
b) What is the median number of sandwiches brought to school?  
c) Work out the mean number of sandwiches brought to school. Give your answer to 1 decimal place.
- 2) 50 hippos were captured over the course of a year and weighed. The results can be seen in the table, below.

Weight of hippo in tonnes	Frequency
$1.4 \leq w < 1.7$	5
$1.7 \leq w < 2.0$	9
$2.0 \leq w < 2.3$	15
$2.3 \leq w < 2.6$	12
$2.6 \leq w < 2.9$	7
$2.9 \leq w < 3.2$	2

Work out an estimate for the mean weight of a hippo. Give your answer to 1 decimal place.

Level 7

N22 C26 C27 C28 C29 C30 C31 A16 A17 A18 A19 A20 A21 A22 A23 A24 A25  
A26 A27 A28 A29 S30 S31 S32 S33 S34 S35 S36 S37 D14 D15

# D14

## Averages from Tables

Jenny had a theory that if asked to guess the length of a line, children under the age of 10 would overestimate the length but adults would underestimate the length.

To help her decide if she was correct she asked 100 under-10s and 100 adults to guess the length of a 34 cm line.

The results can be seen in the two tables, below.

*Children under the age  
of 10 estimates*

Estimate of length in cm	Frequency
$20 \leq l < 24$	4
$24 \leq l < 28$	11
$28 \leq l < 32$	24
$32 \leq l < 36$	39
$36 \leq l < 40$	22

*Adult estimates*

Estimate of length in cm	Frequency
$20 \leq l < 24$	2
$24 \leq l < 28$	6
$28 \leq l < 32$	16
$32 \leq l < 36$	62
$36 \leq l < 40$	14

Use the results in the tables to see if Jenny was correct.  
Show all your workings.

Level 7

N22 C26 C27 C28 C29 C30 C31 A16 A17 A18 A19 A20 A21 A22 A23 A24 A25  
A26 A27 A28 A29 S30 S31 S32 S33 S34 S35 S36 S37 D14 D15

# D15

## Relative Frequency

- 1) Peter bought an unfair dice from a Joke Shop. He didn't know how the dice was biased and so he rolled it 100 times and noted down which numbers came up. He found that the number 6 occurred 8 times.
- What is the relative frequency of getting a six?
  - If Peter rolls the dice 400 times, estimate how many 6s he will roll.
- 2) Mary had a bag containing four different colour marbles. She chose a marble, noted its colour and then replaced it, 80 times.

The results can be seen in this table.

Colour	No. of times chosen
Red	12
Blue	24
Green	18
Yellow	26

- Estimate the probability that a blue marble will be chosen on the next pick.
  - If a marble is chosen and replaced 280 times, estimate how many times you would expect to choose a red marble.
- 3) Benford's law says that if you look at real-life sources of data (heights of mountains, populations of countries, etc) the number 1 will be the first digit with relative frequency 0.3. If you go through any newspaper and write down the first 20 numbers you come across, about how many of the numbers would you expect to begin with a '1'.

Level 7

N22 C26 C27 C28 C29 C30 C31 A16 A17 A18 A19 A20 A21 A22 A23 A24 A25  
A26 A27 A28 A29 S30 S31 S32 S33 S34 S35 S36 S37 D14 D15